

# INSTRUCTION MANUAL

## BR type (BR06, 08, 10, 12)

### Standard Chuck

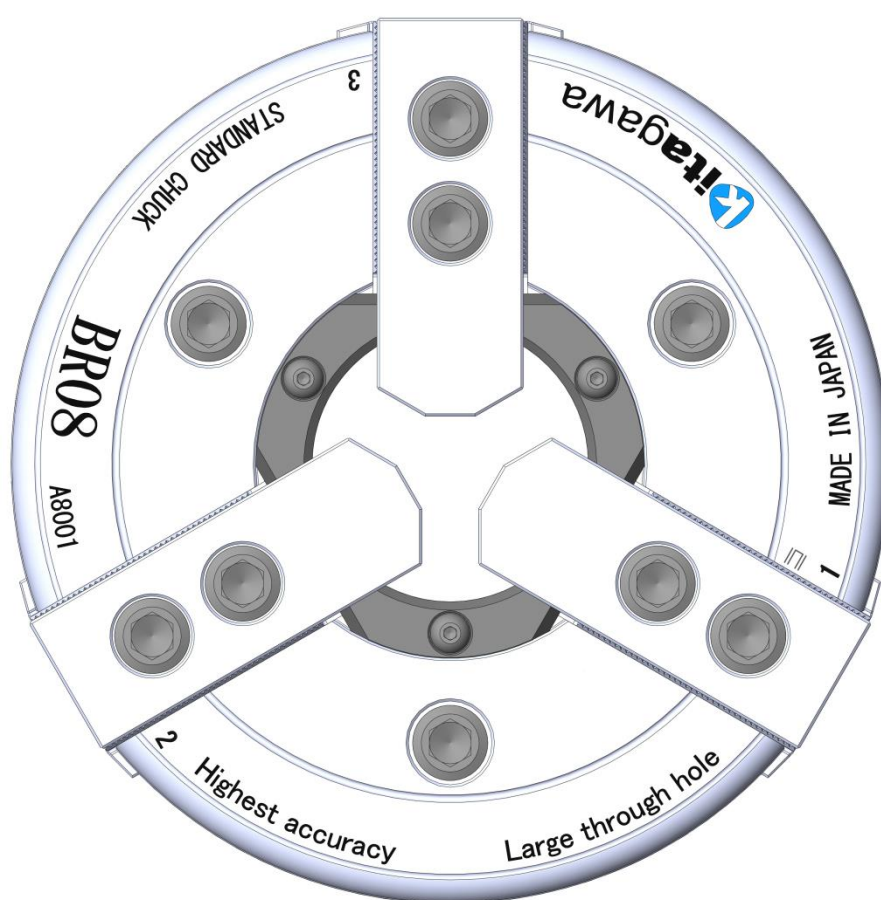

## Kitagawa Corporation

77-1, Motomachi, Fuchu-shi, Hiroshima, 726-8610, Japan

TEL +81-(0)847-40-0526

FAX +81-(0)847-45-8911

Before using this product, be sure to read this manual carefully to understand how to use it correctly.

# Contents

1	Preface	2
	1.1 How to Use This Manual	2
	1.2 Signal Word Definition	3
	1.3 Type Designation	3
	1.4 Application Purpose of This Product	4
	1.5 Unacceptable Application Example	4
	1.6 Structural Drawing	4
	1.7 Product Range	5
	1.8 Warranty	5
	1.9 Parts List	5
2	 Important Safety Precautions	7
3	Technical Data	11
	3.1 Specifications	11
	3.2 Calculation of Operating Condition	13
	3.3 Relationship Between Gripping Force and Rotational Speed	17
	3.4 Relationship Between Gripping Center Height and Static Gripping Force/Input Force	17
	Relationship Between Moment of Mass of Top Jaw and Loss of Gripping Force	
4	Soft Jaw	20
	4.1 Installation of Soft Jaw	20
	4.2 Stroke mark	21
	4.3 External Gripping Soft Jaw Forming Procedure	22
	4.4 Internal Gripping Soft Jaw Forming Procedure	23
	4.5 Tnut-Plus	24
5	Additional Machining Allowable Range	26
6	Maintenance and Inspection	27
	6.1 Periodic Inspection	27
	6.2 Grease Supply	27
	6.3 Disassembly	28
7	Troubleshooting	29
	7.1 Troubleshooting	29
	7.2 Contact Information In Case Problem Occurs	30

8	Installation	31
	8.1 Installation Conceptual Diagram	31
	8.2 Back plate	33
	8.3 Draw Pipe	34
	8.4 Disassembly of Draw Nut and Threading	35
	8.5 Chuck Installation Procedure	35
9	Others	36
	9.1 Standard or Directive to Conform	36
	9.2 Marking of Product	37
	9.3 Disposal	38

## 1. Preface

### 1.1. How to Use This Manual

- This manual provides detailed information on this product so that you can understand its performance and functions and use it safely and correctly. Before using this product, be sure to read this manual carefully to understand how to use it correctly.
- This manual has been prepared for intended use for persons in charge of installation, operation, inspection, and maintenance of this product. When the beginners use this product, be sure to receive the guidance from skilled persons, sales agents, or us in advance.
- Store this manual with care in the specified place at hand, and reread it as necessary for correct use of the product.
- This manual is a part of the product. Do not sell or transfer the product to a third party without attaching this manual.
- Read the section "Important Safety Precautions" at the beginning of this manual especially carefully, which summarizes precautions that particularly you should know or follow.
- Failure to follow the instructions and warnings in this manual could result in serious human accidents. Kitagawa shall not be held liable for human accidents, death, damage, or loss that occurred due to a failure to follow this manual.
- This manual does not predict all potential hazards in installation, operation, maintenance, and inspection under all environmental conditions. Therefore, the matters, unless otherwise mentioned clearly as "can be done" or "may be done" in this manual, should be considered as "cannot be done" or "must not be done".
- Please contact us or our agents if you have an uncertainty about safety when you try to perform installation, operation, inspection, or maintenance of the product.
- The information and product specifications described in this manual are subject to change without notice for the purpose of improvement.

## 1.2. Signal Word Definition



The triangle shown on the left indicates warning. The warning signs are used to alert you to potential safety hazards. To avoid death or injuries that could occur, follow all the instructions given with the warning signs.

Handling precautions that are considered especially important are classified and indicated as shown below according to the degree of risk that could result.

<b>Danger</b>	Failure to follow the safety precautions below will result in death or serious injuries.
<b>Warning</b>	Failure to follow the safety precautions below could result in death or serious injuries.
<b>Caution</b>	Failure to follow the safety precautions below may result in minor or moderate injuries.
<b>Notice</b>	Indicates instructions which, if you do not heed given instructions, could result in damage to the product or shortened service life, or damage to peripheral equipment.

The signs are classified and indicated as follows according to the type of risk.

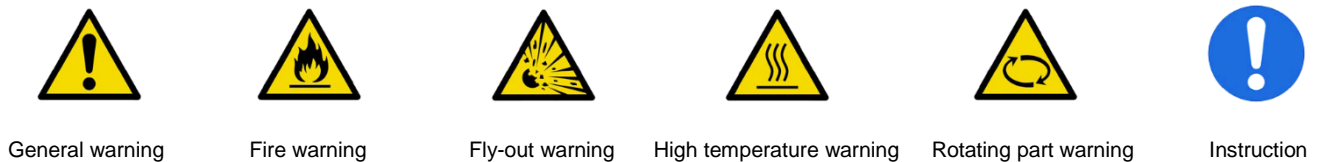

## 1.3. Type Designation

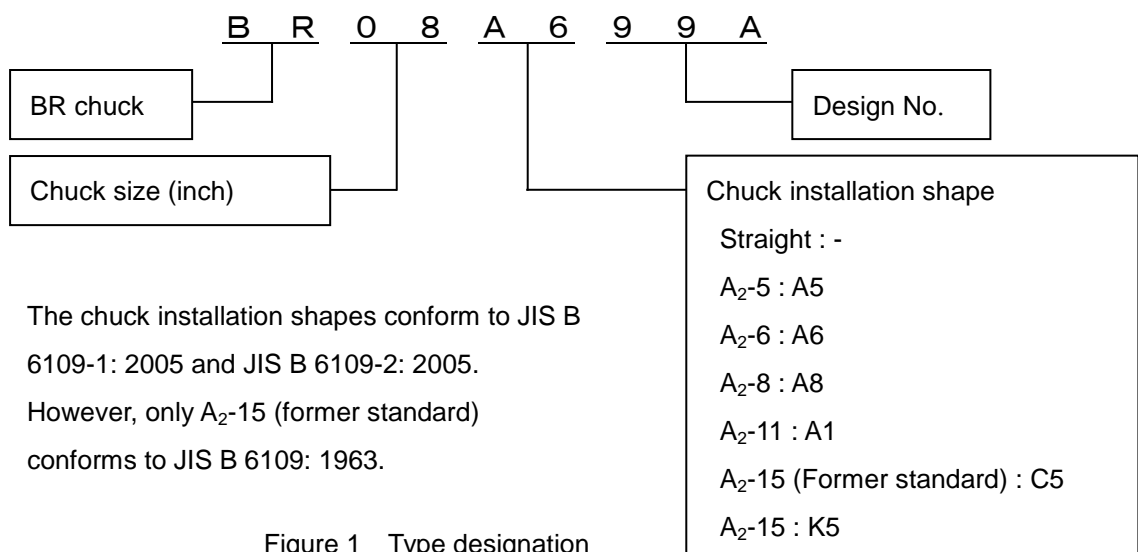

Figure 1 Type designation

#### 1.4. Application Purpose of This Product

The power chuck is installed on machine tools such as NC lathes and machining centres to fix a workpiece. The power chuck is equipped with the jaws to fix the workpiece and they are opened and closed by means of a rotary cylinder. For any other applications, please contact us.

#### 1.5. Unacceptable Application Example

The power chuck is not designed for the applications mentioned below for example.

- To fix an object to be pressed, punched, welded or fused
- To use as a tool holder
- To suspend or transfer an object
- To fix another chuck that grips a workpiece

#### 1.6. Structural Drawing

The power chuck and rotary hydraulic cylinder are respectively installed on both side of the machine spindle and connected with the draw pipe.

The hydraulic pressure applied to the cylinder is converted to thrust that pulls the draw pipe and operates the wedge plunger backward via the draw pipe. Then the master jaw is operated inwardly by the wedge hook and the force is transferred to the top jaw.

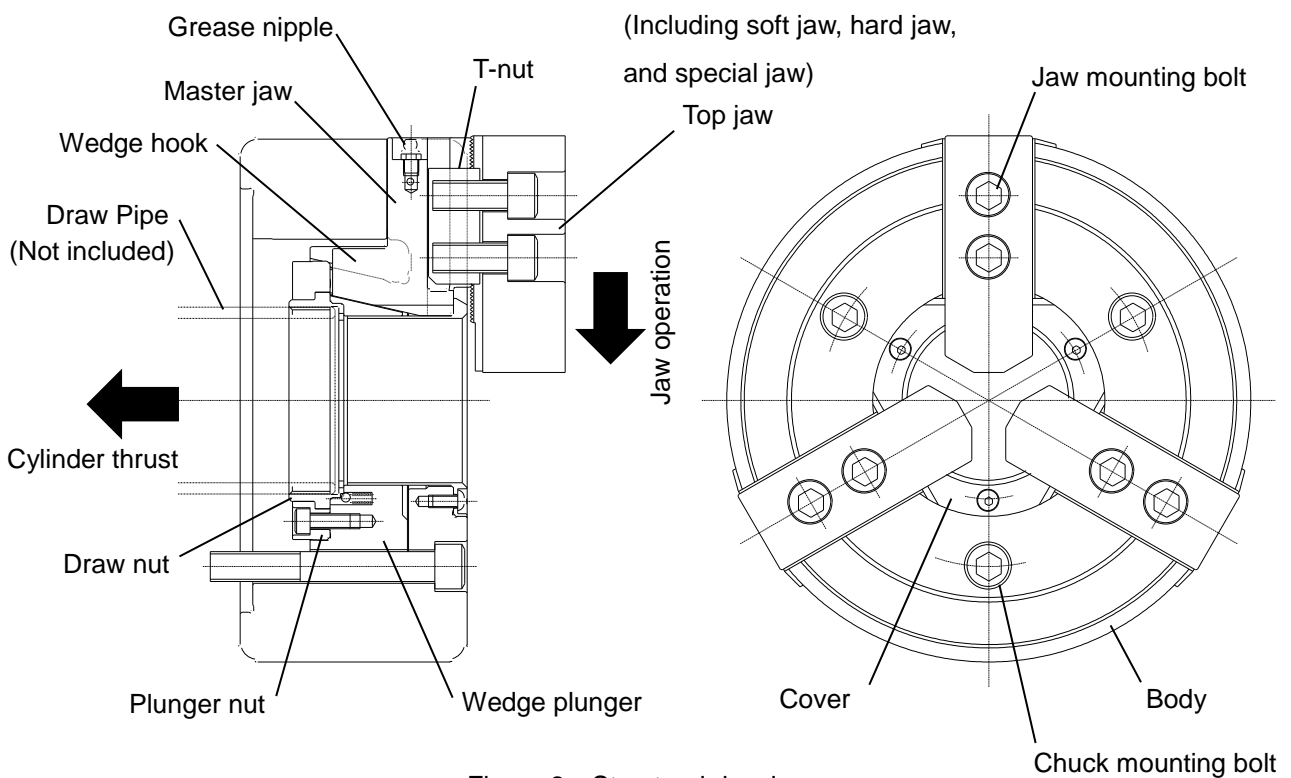

Figure 2 Structural drawing

## 1.7. Product Range

- This is the chuck instruction manual.

For the cylinder and other peripheral devices, refer to their respective instruction manuals.

## 1.8. Warranty

The product is warranted for one year after the date of delivery. However, the following cases will void the warranty.

- When parts other than Kitagawa's genuine parts are used.
- When proper maintenance and inspection such as periodic greasing are not performed.
- Other than above, when the product is used in methods not following this manual.

## 1.9. Parts List

All parts used including consumables shall be genuine parts delivered by Kitagawa.

Kitagawa shall not be held liable for human accidents, death, damage, or loss that occurred due to the use of non-genuine parts.

Table 1 Standard delivery range

No.	Parts name	Quantity	No.	Parts name	Quantity
1	Body	1	9	Coil spring	1
2	Wedge plunger	1	10	Plate wrench for draw nut *2	1
3	Master jaw	3	11	Chuck mounting bolt	3
4	Soft jaw *1	3	12	Jaw mounting bolt *1	6
5	T-nut *1	3	13	Plunger nut mounting bolt	9 / 12
6	Plunger nut	1	14	Cover mounting bolt	3
7	Draw nut	1	15	Steel ball	1
8	Cover	1	16	Grease nipple	3

\*1 : Consumables

\*2 : Accessory tool

Table 2 Optional parts

No.	Parts name	Quantity	No.	Parts name	Quantity
17	Back plate	1	20	O-ring	1
18	Back plate mounting bolt	3 / 6 / 9	21	Tnut-Plus *1	3
19	Cap	1			

\*1 : Consumables

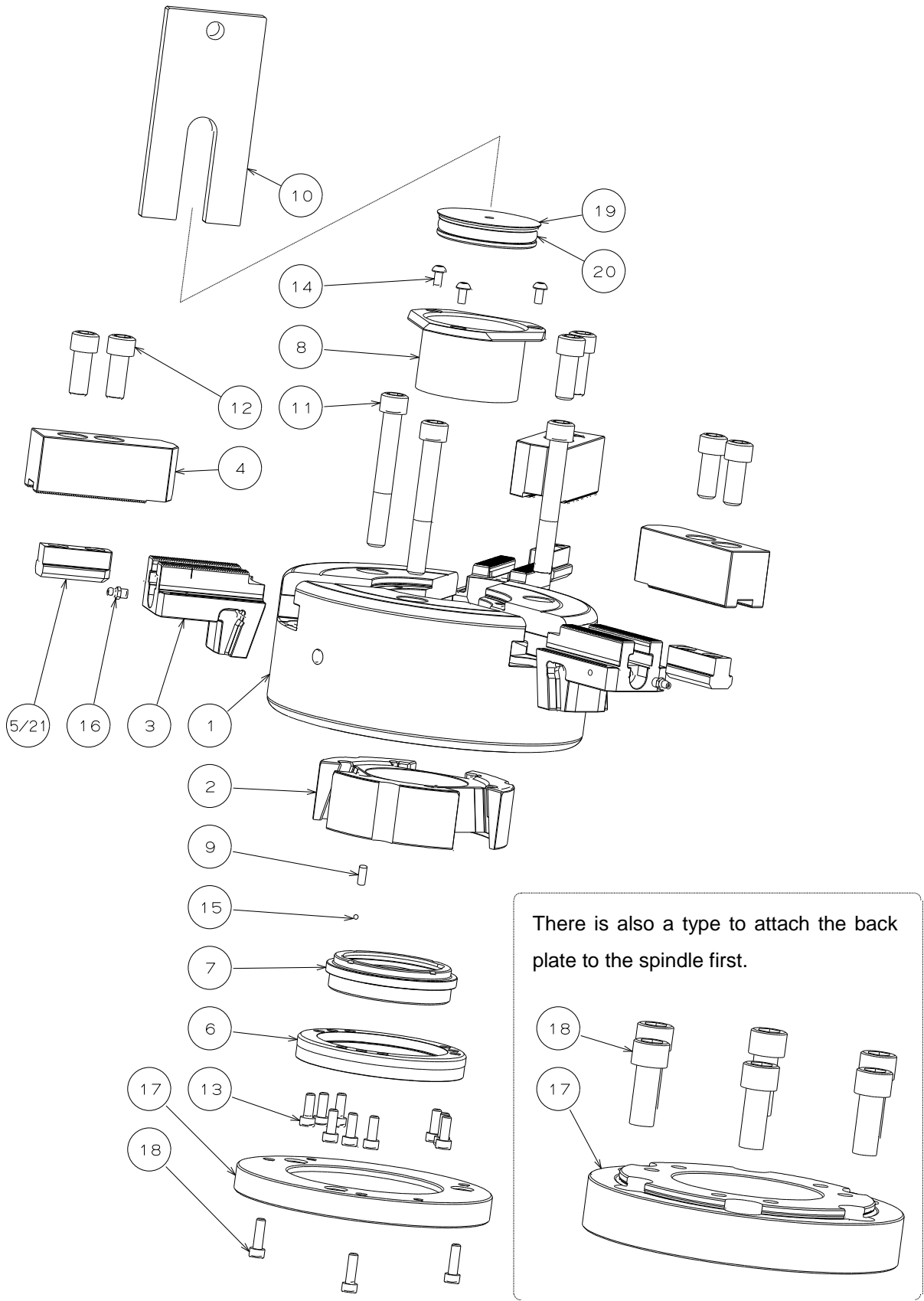

Figure 3 Parts



## 2. Important Safety Precautions

This chapter summarizes precautions that particularly you should know or follow.

Please read them before starting to use the product.



**Danger** Failure to follow the safety precautions below will result in death or serious injuries.



**Turn off the main power supply of the machine when installing, inspecting, greasing, or replacing the chuck.**

- The chuck may rotate unexpectedly and entangle your body or clothing.



**Do not rotate the spindle with the door open.**

**Provide an interlock to allow spindle rotation only when the door is closed.**

- If the door is not closed, the rotating chuck may entangle your body or clothing or cause the workpiece to fly out.



**Do not turn OFF the hydraulic pump or operate the solenoid valve during spindle rotation.**

**Before performing workpiece transfer during spindle rotation on an opposed 2-spindle lathe, confirm the machine manufacturer that the operation can be performed safely.**

- Operating the solenoid valve during spindle rotation will drop or block the hydraulic pressure, causing the gripping force to drop suddenly and the workpiece to fly out.



**The rotational speed and input force must not exceed the limit in operation. (Refer to "3. Technical Data")**

- Excessive rotational speed may cause the workpiece to fly out.
- Excessive input force may damage the chuck, causing the workpiece to fly out.



**Only the machine manufacturer or the user is to determine cutting conditions, gripping force, and rotational speed according to test cutting result. Adjust the hydraulic pressure so as to obtain the gripping force necessary for machining, and confirm that the necessary gripping force is obtained before starting machining.**

- Insufficient gripping force may cause the workpiece to fly out.



**If you use a top jaw higher or heavier than the standard top jaw, determine the operating condition according to "3.2. Calculation of Operating Condition" on page 13.**

- Using a top jaw under excessive operating conditions may damage the chuck, causing the workpiece to fly out.



**For internal gripping, use the chuck with 1/2 or less of the max. permissible input force for external gripping.**

- Excessive input force may damage the chuck, causing the workpiece to fly out.



**When using fixed jaws instead of one or two top jaws, the input force must be 2/3 or less or 1/3 or less of the max. permissible input force.**

- Since the input force that is normally applied to three jaws evenly is concentrated in two or one jaw, the chuck may be damaged, causing the workpiece to fly out.



**The gripping diameter must be equal to or less than the body outside diameter.**

- Using the chuck with the gripping diameter exceeding the body outside diameter may damage the chuck, causing the workpiece to fly out.



**When machining a workpiece with a long protrusion, support it with the steady rest or the tailstock.**

- If not, the workpiece may turn at the end, causing the workpiece to fly out.





**Do not grip a workpiece with slope shapes or tapered shapes such as a cast.**

- Otherwise, the workpiece may slip, causing it to fly out.



**If a workpiece or jig causes an unbalance, reduce the rotational speed or correct the state by mounting a balance weight. The recommended balance quality is G6.3 or less in JIS B 0905:1992.**

- An unbalanced workpiece generates centrifugal force, causing the workpiece to fly out.
- Vibration generated by the unbalance may damage the chuck, causing the workpiece to fly out.



**Confirm that the chuck or workpiece does not interfere with the cutter or the turret at a low rotational speed before starting machining.**

- A large impact on the chuck or workpiece by interference may damage the chuck, causing the chuck or workpiece to fly out.



**If an impact is given to the machine by interference between the chuck/workpiece and the cutter/turret due to malfunction or program errors, immediately stop rotation. Then thoroughly check for damage or crack on the parts by disassembling and cleaning them and perform repair or replacement if necessary. (Refer to page 28.)**

- The impact may cause damage or crack on the parts. Continuous use of faulty parts may damage the chuck, causing the workpiece to fly out.



**Use the chuck and cylinder that are both manufactured by Kitagawa.**

**If you must use the chuck together with a cylinder manufactured by another company, confirm Kitagawa or sales agents that the combination of the chuck and the cylinder is safe.**

- Depending on the combination with a particular cylinder, the chuck and the cylinder may be damaged, causing the workpiece to fly out.



**Be sure to tighten the bolts with the specified torque listed in Table 3-1 and Table 3-2.**

**Use a proper tool that can control torque such as a torque wrench.**

**Use only the bolts attached to the chuck. Do not use other bolts.**

- Rotating the chuck with the jaw mounting bolts loosened may cause the jaws and workpiece to fly out.
- If insufficient bolts are mounted, bolt length is wrong, or tightening torque is improper, the bolts may be damaged, causing the chuck and workpiece to fly out.

Table 3-1 Specified torque for hex. socket head cap screw

Thread size	M5	M6	M8	M10	M12	M14	M16	M20	M22	M24
Tightening torque [N·m]	7.5	13	33	73	107	171	250	402	539	666

\* Strength classification: M20 or smaller = 12.9, M22 or larger = 10.9

Table 3-2 Specified torque for hex. socket button head screw

Thread size	M3	M4	M5	M6	M8	M10	M12	M16
Tightening torque [N·m]	1.4	3.2	6.4	10.8	26.3	52.1	90.9	224



**Prevent your hands and fingers from being caught when gripping a workpiece with the chuck. (To prevent risks, it is recommended to automate the workpiece attaching/detaching operation.)**

- Otherwise, your hands and fingers may be crushed or cut off.



**If any of the abnormalities shown below suddenly occurs during operation, it may be a sign of damage of the chuck.**

- ✓ The workpiece slips.
- ✓ Machining accuracy has become worse.
- ✓ Chuck gripping force is reduced.
- ✓ Chattering occurs.
- ✓ Machine vibration has been increased.

(Gripping force is not increased even by increasing hydraulic pressure.)

If the status is not improved even after taking the measures described on page 29, immediately stop using the chuck.

- Continuous use of faulty parts may damage the chuck, causing the workpiece to fly out.

If the cylinder combined is to be changed due to such as model change of a rotary hydraulic cylinder, change the hydraulic pressure accordingly so as to obtain proper gripping force.

- Use of the chuck under low hydraulic pressure leads to insufficient gripping force, causing the workpiece to fly out.
- Use of the chuck under high hydraulic pressure leads to damage of the chuck, causing the workpiece to fly out.



For machine manufacturers

The draw pipe must have sufficient strength with respect to the operating conditions, not causing run-out and unbalance. The thread accuracy must be 6H / 6g. Tighten the thread securely with a sufficient penetration length.

- Insufficient strength of the draw pipe, vibration due to unbalance, and looseness of the thread may damage the draw pipe. If the draw pipe is broken, the gripping force is lost instantaneously, causing the workpiece to fly out.



For machine manufacturers

Use a lock valve (check valve) built-in type cylinder. (According to JIS B 6150 : 2015, the cylinder must be provided with equipment such as a check valve so as to maintain the pressure for a certain period of time when the hydraulic pressure to the cylinder is blocked.) Design the hydraulic circuit so that the solenoid valve holds the gripping port position when the current is not applied.

- Sudden drop or interruption of hydraulic pressure due to power failure or hydraulic pump failure will lose the gripping force instantaneously, causing the workpiece to fly out.

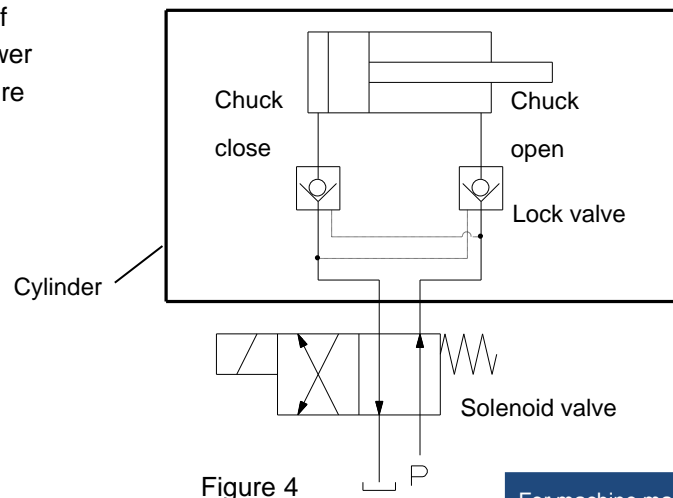

For machine manufacturers

Use a stroke control sensor built-in type cylinder. (According to JIS B 6150 : 2015, the cylinder must be provided with equipment such as a stroke control sensor so that the power chuck or the cylinder ensures effective generation of the gripping force.)

- If the jaw stroke becomes insufficient due to chips accumulating inside the chuck or loosened draw nut, the chuck may not grip the workpiece, causing the workpiece to fly out.



For machine manufacturers



## Warning

Failure to follow the safety precautions below could result in death or serious injuries.

	<p><b>Perform additional machining of tapped holes and pin holes on the chuck only within the allowable range.(Refer to page 26.)</b></p> <ul style="list-style-type: none"> <li>• Additional machining performed out of the allowable range may damage the chuck, causing the workpiece to fly out.</li> <li>• Especially, additional machining to the master jaws and T-nut directly causes fly-out of the workpiece.</li> </ul>
	<p><b>Supply grease every day.</b></p> <p><b>When supplying grease, turn OFF the machine main power and be sure to use the specified grease. (Refer to page 27.)</b></p> <ul style="list-style-type: none"> <li>• Insufficient greasing or use of grease other than the specified one may drop the gripping force, causing the workpiece to fly out.</li> </ul>
	<p><b>Disassemble and clean the chuck every six months or 100,000 strokes (cast machining: every two months). (Refer to page 28.)</b></p> <ul style="list-style-type: none"> <li>• Omitting the disassembly and cleaning and use of the chuck with chips and coolant remaining inside the chuck will lead to insufficient stroke and gripping force drop, causing the workpiece to fly out.</li> </ul>
	<p><b>Remove the eye bolts and wrench from the chuck after use.</b></p> <ul style="list-style-type: none"> <li>• Rotating the chuck without removing the eye bolts and wrench may cause them to fly out.</li> </ul>
	<p><b>Use rustproof coolant.</b></p> <ul style="list-style-type: none"> <li>• Otherwise, rust that will be formed inside the chuck may drop the gripping force, causing the workpiece to fly out.</li> </ul>
	<p><b>When stopping the machine for a long time or when storing the chuck without using it for a long period, supply grease and rustproof them beforehand.</b></p> <ul style="list-style-type: none"> <li>• Otherwise, rust that will be formed inside the chuck may drop the gripping force, causing the workpiece to fly out.</li> </ul>
	<p><b>Do not wear clothing or accessories such as gloves and necktie which are easy to be caught in.</b></p> <ul style="list-style-type: none"> <li>• Otherwise, your body or clothing may be entangled.</li> </ul>
	<p><b>Do not perform the work after drinking alcohol or taking medicine.</b></p> <ul style="list-style-type: none"> <li>• Impaired judgment or operation mistake may cause serious hazards.</li> </ul>



## Caution

Failure to follow the safety precautions below may result in minor or moderate injuries.

	<p><b>Do not touch machined workpieces with bare hands. (To prevent risks, it is recommended to automate the workpiece attaching/detaching operation.)</b></p> <ul style="list-style-type: none"> <li>• Touching workpieces with bare hands may cause a burn because the workpieces may be very hot.</li> </ul>
	<p><b>Remove the workpiece from the chuck when stopping the machine for a long time.</b></p> <ul style="list-style-type: none"> <li>• Failure to do so may lead to drop or interruption of hydraulic pressure or malfunction of the cylinder, causing the workpiece to drop.</li> </ul>
	<p><b>When attaching/detaching the chuck to/from the machine, use appropriate lifting devices such as eye bolts and a floor-operated crane.</b></p> <ul style="list-style-type: none"> <li>• Lifting a heavy chuck by hands will cause a backache.</li> <li>• Slipping and dropping the chuck from hands may result in a bruise.</li> </ul>

### 3. Technical Data

#### 3.1. Specifications

Table 4-1 Specification table

Type		BR06	BR08	BR10	BR12	
Plunger stroke	mm	12	16	19	23	
Jaw stroke (in diameter)	mm	5.5	7.4	8.8	10.6	
Max. permissible speed	min <sup>-1</sup>	6000	5000	4500	3500	
Through hole diameter	mm	53	66	81	106	
External gripping	Max. permissible input force	kN	23	35	49	60
	Max. static gripping force	kN	58.5	90	123	156
	Max. permissible hydraulic pressure (operating cylinder) *1	MPa	2.3 (SR1453)	3.2 (SR1566)	3.4 (SR1781)	3.4 (SR2010)
			2.1 (SS1453K)	2.5 (SS1666K)	3.1 (SS1881K)	3.0 (SS2110K)
	Dynamic gripping force at max. speed	kN	22.5	36	44	53
	Gripping range	mm	φ16~170	φ22~210	φ31~254	Φ44~315
Internal gripping	Max. permissible input force	kN	11.5	17.5	24.5	30
	Max. static gripping force	kN	29.3	45	61.5	78
	Max. permissible hydraulic pressure (operating cylinder) *1	MPa	1.2 (SR1453)	1.6 (SR1566)	1.7 (SR1781)	1.7 (SR2010)
			1.1 (SS1453K)	1.3 (SS1666K)	1.6 (SS1881K)	1.6 (SS2110K)
Mass *2	kg	12.8	22.2	35.8	57.0	
Moment of inertia *3	kg·m <sup>2</sup>	0.052	0.14	0.32	0.80	
Standard soft jaw type		SJ06B1	SJ08B1	SJ10B1	SJ12N1	
Tnut-Plus type (option)		TN06PLUS	TN08PLUS	TN10PLUS	TN12PLUS	
Balance quality of chuck body *4		JIS B 0905 : 1992 G6.3				
Storage temperature / operating temperature *5		-20~+50°C / -10~+40°C				

\*1 : The max. permissible hydraulic pressure differs depending on the cylinder used.

Set the hydraulic pressure according to the cylinder type.

\*2 : The mass is a value when the standard soft jaws and chuck mounting bolts are included.

\*3 : The moment of inertia is obtained by including the standard soft jaws and chuck mounting bolts.

Here, the soft jaws are mounted to the position protruding outward from the master jaws by a half pitch at the center of the jaw stroke.

\*4 : The balance quality of the chuck body is a value when the soft jaws, T-nut, and jaw mounting bolts are not included.

\*5 : When storing the product, it should be subjected to the antirust treatment and stored in a place free from wetting, condensation, or freeze.

Table 4-2 Specification table (when optional small-diameter gripping soft jaws are used)

Type		BR08
Small-diameter gripping soft jaw		SJ08S1
Gripping range in external gripping	mm	φ12~210

The max. static gripping force in the specifications is the value to be obtained under the following conditions.

- At the max. permissible input force
- Kitagawa's standard soft jaws are used.
- The soft jaw mounting bolts are tightened to the specified torque. (Refer to page 8.)
- The gripping meter is gripped at the center of the jaw stroke. Here, the soft jaws are attached to the position where the soft jaw circumference side end face and the chuck circumference are almost aligned.
- The gripping force is measured by the Kitagawa's gripping meter, and the height of the gripping position is as shown in Figure 5. (Also refer to Table 5)
- The specified grease is used. (Refer to page 27.)
- A variable capacity type pump having a delivery capacity of 20 L/min or more is used as the hydraulic pressure source.
- The pressure is set by the regulator of the pump or that separately provided.

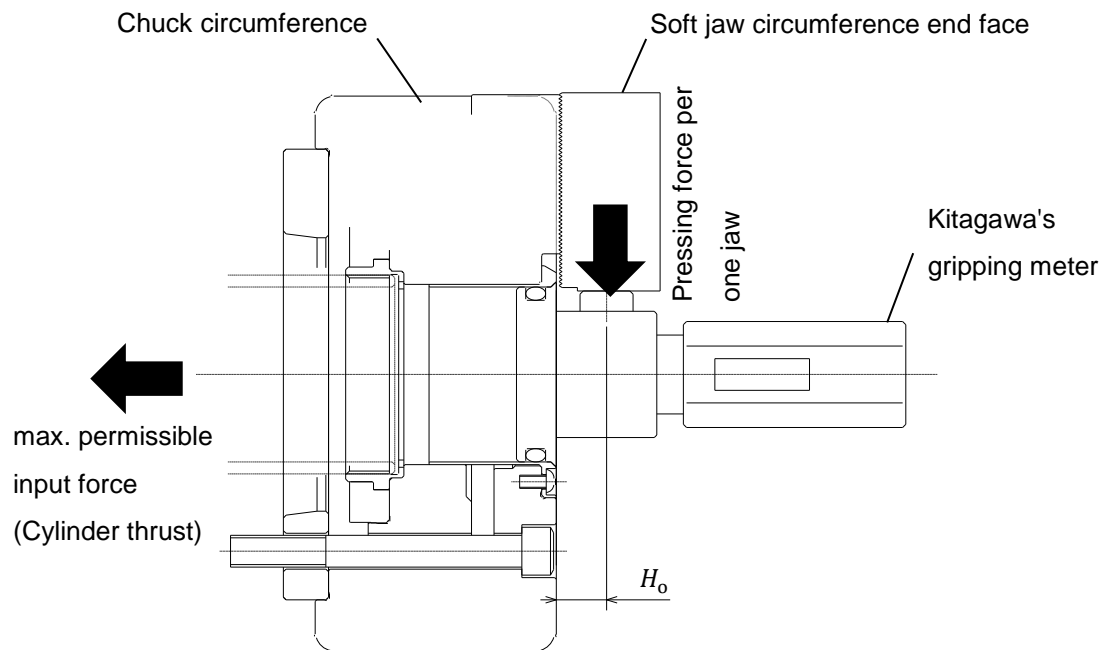

Figure 5 Gripping force measuring method

\* The gripping meter indicates the pressing force per one jaw. The gripping force is the total of the pressing forces of all jaws.

### 3.2. Calculation of Operating Condition

Table 5 Symbols for calculation and the meanings

Symbol	Meaning		BR06	BR08	BR10	BR12	
$H_o$	Gripping center height in specifications	mm	19	21	23	27	
$H$	Gripping center height in operation	mm	-	-	-	-	
$H_T$	Top surface height of standard soft jaw	mm	33	39	43	52	
$H_{max}$	Gripping part center limit height (recommended value)	mm	60	70	80	90	
$F_{g\ max}$	Max. static gripping force	External gripping	kN	58.5	90	123	156
		Internal gripping	kN	29.3	45	61.5	78
$F_{gH}$	Static gripping force with $H$ at max. permissible input force	kN	-	-	-	-	
$F_g$	Static gripping force in operation	kN	-	-	-	-	
$F_{gD}$	Dynamic gripping force in operation	kN	-	-	-	-	
$Q_{max}$	Max. permissible input force	External gripping	kN	23	35	49	60
		Internal gripping	kN	11.5	17.5	24.5	30
$Q$	Input force in operation	kN	-	-	-	-	
$m_o$	Mass of one standard soft jaw	kg	0.424	0.782	1.20	1.782	
$m$	Mass of one top jaw used	kg	-	-	-	-	
$r_o$	Gravity radius of standard soft jaw	mm	49.4	64.9	71.3	98.4	
$r$	Gravity radius of top jaw used	mm	-	-	-	-	
$z$	Number of jaws		3	3	3	3	
$n_{max}$	Max. permissible speed	min <sup>-1</sup>	6000	5000	4500	3500	
$n$	Rotational speed in operation	min <sup>-1</sup>	-	-	-	-	
$F_{c\ max}$	Loss of gripping force at max. permissible speed	kN	36	54	79	103	
$F_c$	Loss of gripping force at rotational speed during operation	kN	-	-	-	-	
$\Delta F_c$	Loss of gripping force of moment of mass increase	kN	-	-	-	-	
$A$	Coefficient specific to each type		231	349	377	473	
$B$			21	24	25	27	

### 3.2.1. Calculation of Static Gripping Force at Gripping Center Height $H$

The gripping center height is the distance from the mechanical center point of the gripping force acting on the workpiece to the chuck surface.

When the gripping surfaces of the top jaws contact the workpiece evenly, the mechanical center point of the gripping force is at the center of the gripping surface. If the gripping surfaces contact unevenly or estimation of the gripping center height is difficult, the gripping force should be calculated using the distance from the top jaw top surface to the chuck surface so as to give priority to safety.

- When the gripping center becomes higher, the static gripping force is decreased even if the input force is the same.
- If the gripping center height is higher than, load to be applied to the master jaws, T-nuts, and jaw mounting bolts will increase. To prevent these parts from being damaged, the input force must be reduced to suppress the gripping force to a low level.
- It is recommended to adjust the gripping center height to be  $H_{max}$  or less.

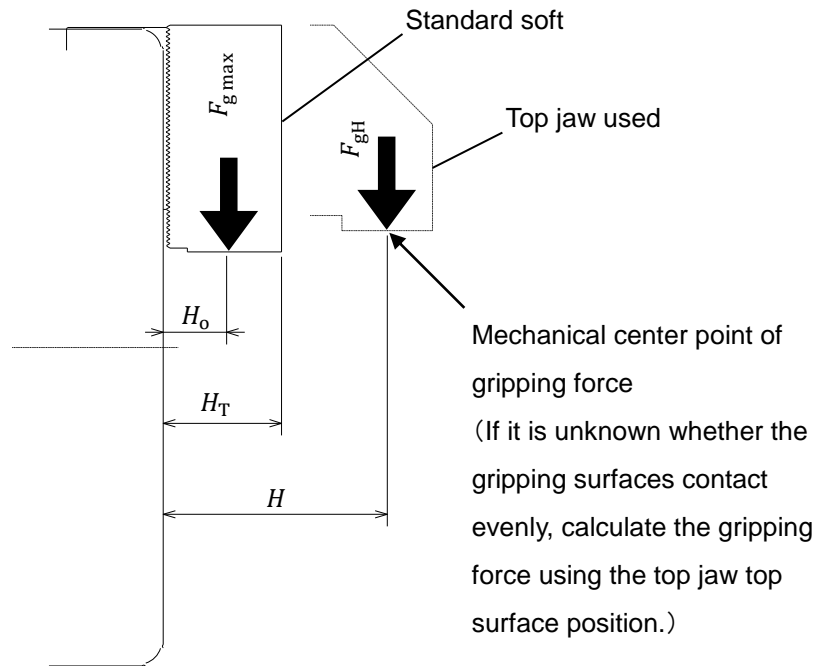

Figure 6 Gripping center height

- $H$  when  $H_T$  is or less

$$F_{gH} = F_{gmax} \times \frac{H_o + A}{H + A}$$

- $H$  when  $H_T$  is more than

$$F_{gH} = F_{gmax} \times \frac{H_o + A}{H + A} \times \frac{H_T + B}{H + B}$$

### 3.2.2. Calculation of Loss of Gripping Force due to Centrifugal Force

Centrifugal force is produced on the jaws during chuck rotation. It acts in the direction reducing the gripping force especially in external gripping. This is called "loss of gripping force due to centrifugal force".

Loss of gripping force due to centrifugal force is proportional to the square of the rotational speed, and thorough consideration is necessary especially for high speed rotation. In addition, a larger mass or gravity radius of the top jaws will increase loss of gripping force due to centrifugal force.

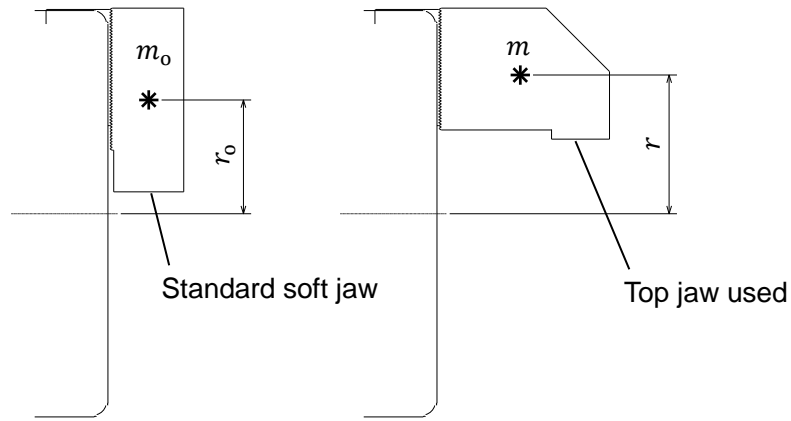

Figure 7 Loss of gripping force due to centrifugal force

- $m \times r$  when  $m_o \times r_o$  is more than

$$\Delta F_c = z \times (m \times r - m_o \times r_o) \times \left( \frac{2 \times \pi \times n}{60} \right)^2 \times 10^{-6}$$

$$F_c = F_{c \max} \times \frac{n^2}{n_{\max}^2} + \Delta F_c$$

- $m \times r$  when  $m_o \times r_o$  is or less

$$F_c = F_{c \max} \times \frac{n^2}{n_{\max}^2}$$

### 3.2.3. Determination of Gripping Force

Determine  $F_g$  in consideration of gripping force loss due to centrifugal force and necessary operating conditions such as cutting conditions, workpiece distortion, and strength of the top jaws. However,  $F_g$  must be  $F_{gH}$  or less. The dynamic gripping force during rotation  $F_{gD}$  is calculated as indicated below.

- For external gripping

$$F_{gD} = F_g - F_c$$

- For internal gripping

$$F_{gD} = F_g + F_c$$



### 3.2.4. Calculation of Input Force for Operation

Calculate the input force required to obtain the necessary gripping force.

- $H$  when  $H_T$  is or less

$$Q = Q_{\max} \times \frac{F_g}{F_{gH}}$$

- $H$  when  $H_T$  is more than

$$Q = Q_{\max} \times \frac{F_g}{F_{gH}} \times \frac{H_T + B}{H + B}$$

### 3.2.5. Calculation of Hydraulic Pressure in Operation

Calculate the hydraulic pressure to be applied to the rotary hydraulic cylinder to obtain the necessary input force.

The following description is predicated on the use of Kitagawa's SR cylinder or SS-K cylinder. When using another cylinder, refer to its instruction manual.

$$P = (P_{c \max} - 0.25) \times \frac{Q}{Q_{c \max}} + 0.25$$

When the hydraulic pressure in operation is less than 0.5 MPa, the cylinder may not operate or the operation speed may become extremely slower.

In this case, it is necessary to increase the input force or select the cylinder again.

Table 6-1 Combination with SR cylinder

Symbol	Meaning		SR1453	SR1566	SR1781	SR2010
$Q_{c \max}$	Max. thrust of cylinder	External gripping kN	43.9	45	58.7	71.8
		Internal gripping kN	47.9	49.7	64.3	75.5
$P_{c \max}$	Max. permissible hydraulic pressure of cylinder MPa		4.2	4.0	4.0	4.0

Table 6-2 Combination with SS-K cylinder

Symbol	Meaning		SS1453K	SS1666K	SS1881K	SS2110K
$Q_{c \max}$	Max. thrust of cylinder	External gripping kN	52.1	65	73.1	71
		Internal gripping kN	56.5	70.6	79.5	74.7
$P_{c \max}$	Max. permissible hydraulic pressure of cylinder MPa		4.5	4.5	4.5	3.5

### 3.3. Relationship Between Gripping Force and Rotational Speed

The graphs in Figure 8 indicate the relationship between the gripping force in each moment of mass of the top jaw and the rotational speed. They can be used for approximate calculation of operating conditions.

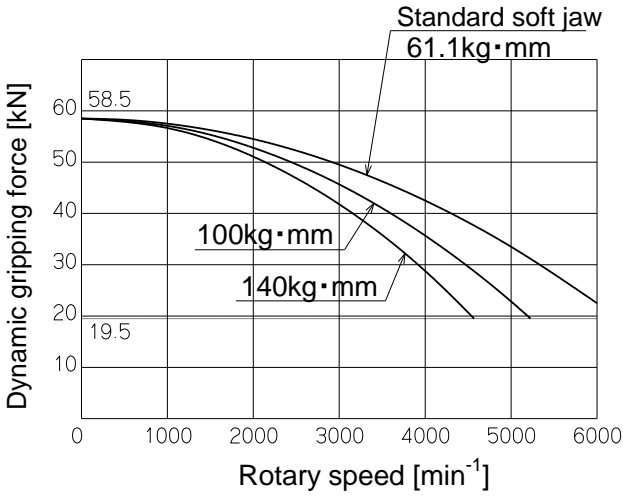

Figure 8-1 BR06

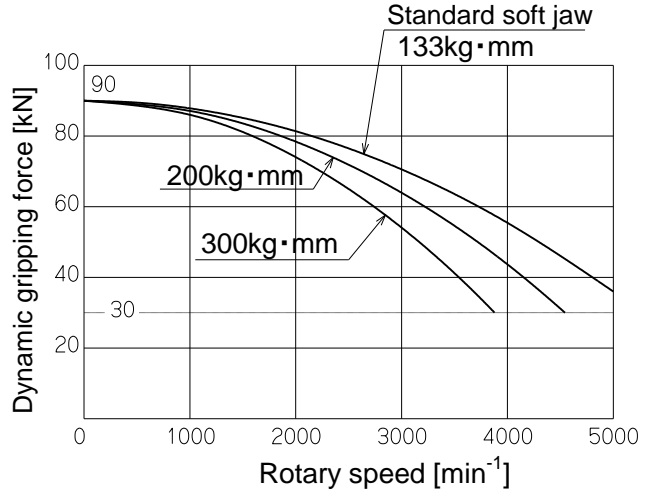

Figure 8-2 BR08

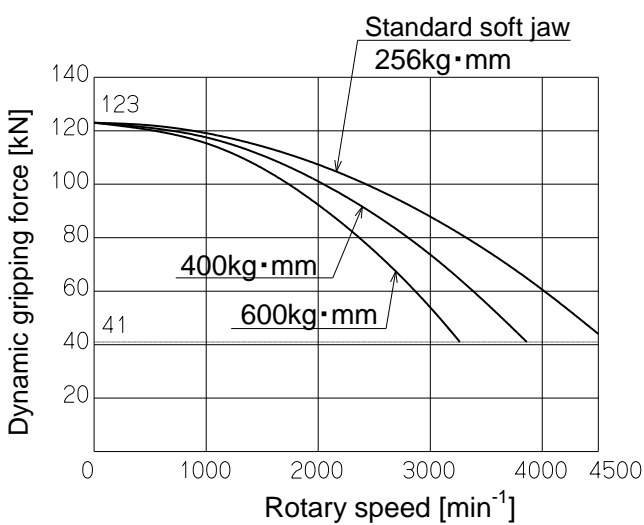

Figure 8-3 BR10

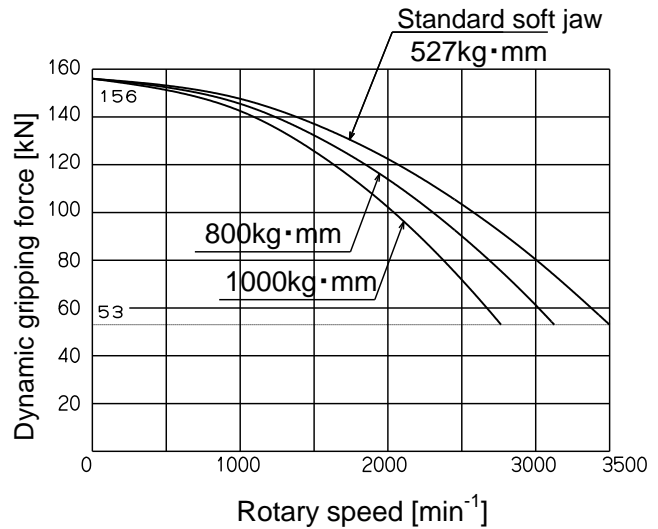

Figure 8-4 BR12

### 3.4. Relationship Between Gripping Center Height and Static Gripping Force / Input Force Relationship Between Moment of Mass of Top Jaw and Loss of Gripping Force

The graphs in Figure 9 indicate the relationship between the gripping center height and the static gripping force/input force, and the relationship between the moment of mass of the top jaw and the loss of gripping force, respectively. They can be used for approximate calculation of operating conditions.

How to read the graphs is explained below taking BR08 for example.

- When the gripping center height is 21 mm and the input force is 35 kN, the gripping force is 90 kN.
- If the gripping center height exceeds 39 mm, the input force must be reduced. For example, when the gripping center height is 50 mm, the input force is limited to 30 kN or less.
- It is recommended to use the chuck with the gripping center height adjusted to 70 mm or less.
- According to JIS B 6150 : 2015, the loss of gripping force due to centrifugal force must not exceed 2/3 (67%) of the actual static gripping force. Therefore, the permissible loss of gripping force is 60 kN when the static gripping force is 90 kN.
- The loss of gripping force due to centrifugal force is 54 kN when the moment of mass of the top jaw is 133 kg·mm and the rotational speed is 5000 min<sup>-1</sup>.

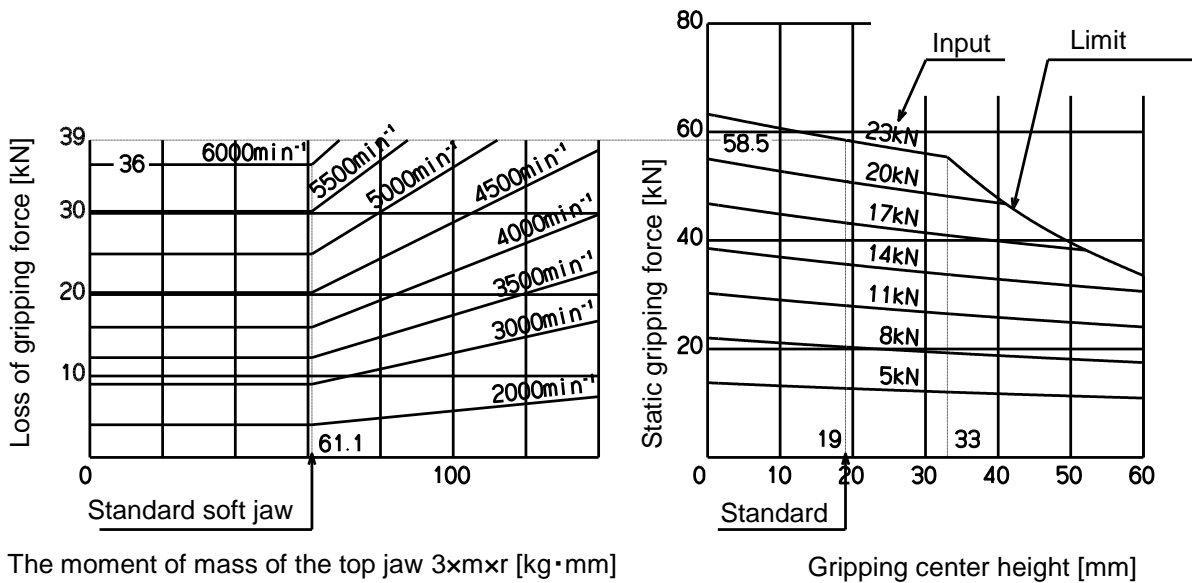

Figure 9-1 BR06

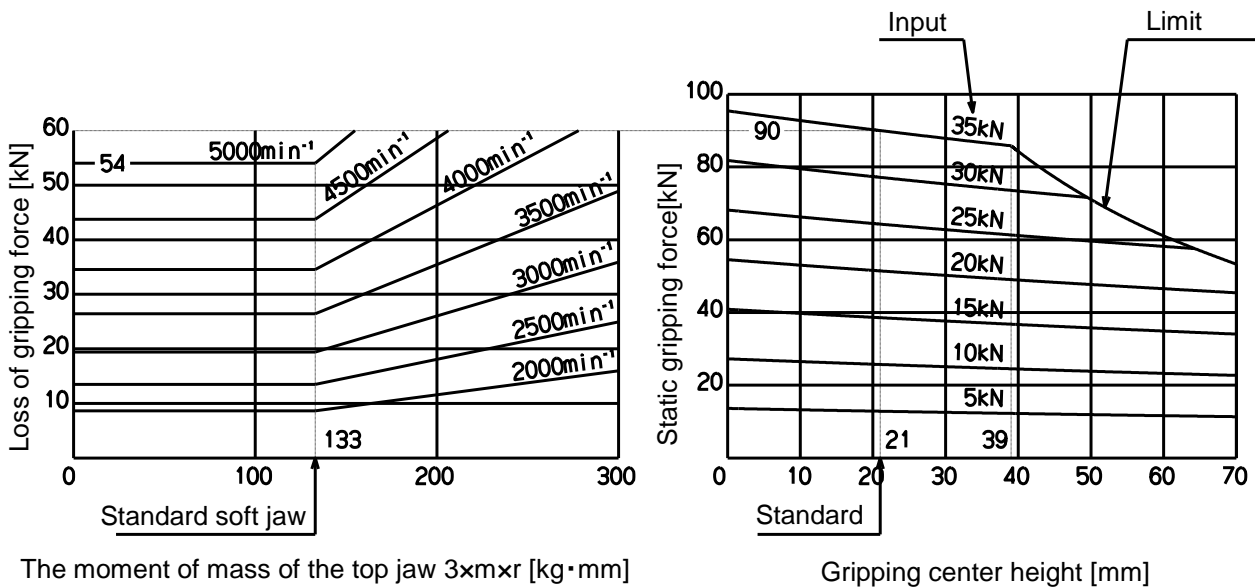

Figure 9-2 BR08

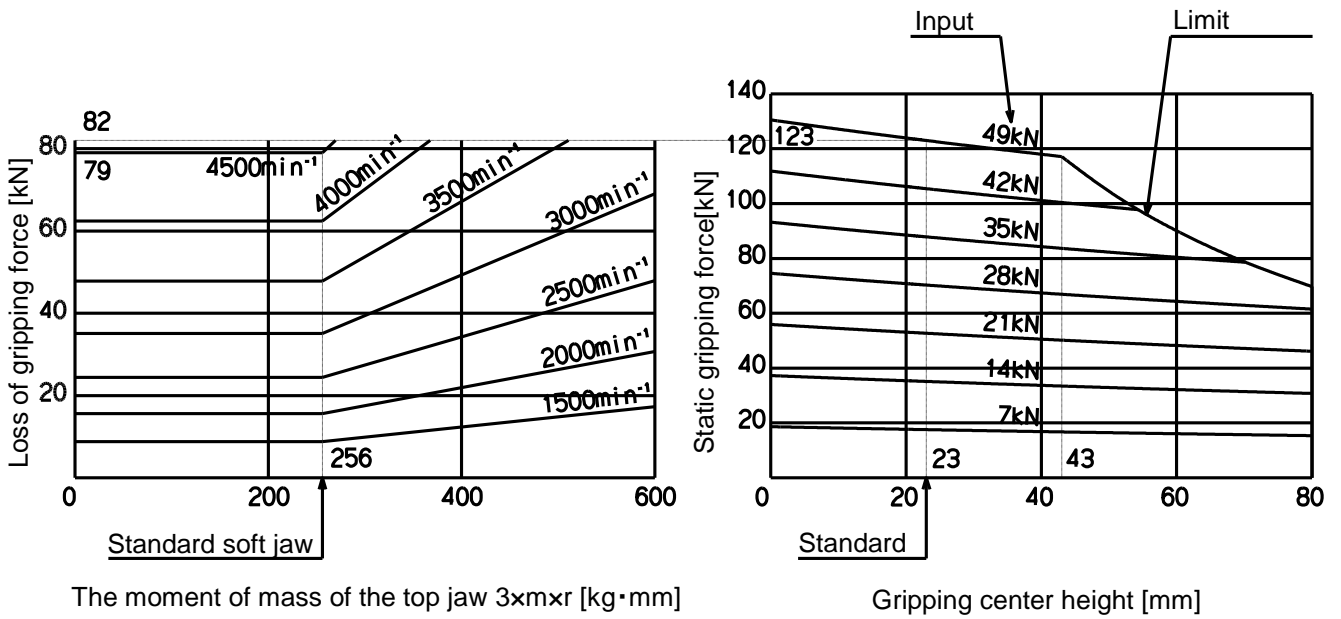

Figure 9-3 BR10

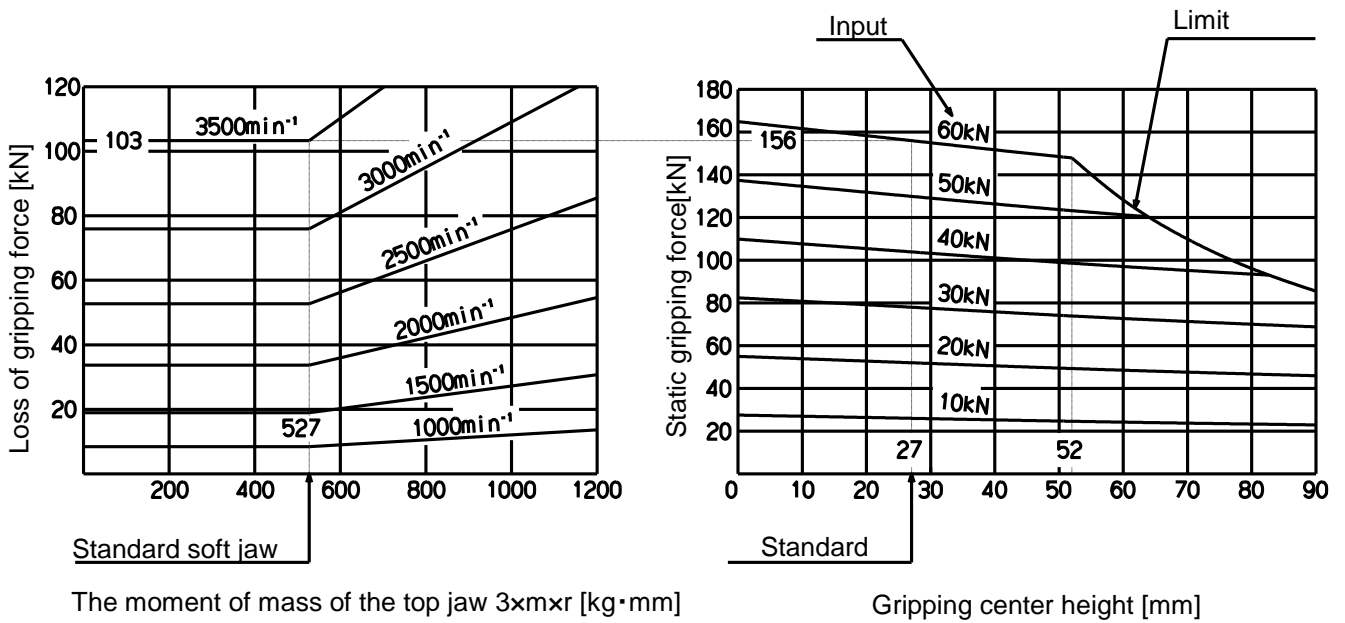

Figure 9-4 BR12

## 4. Soft Jaw

### 4.1. Installation of Soft Jaw

The soft jaw mounting positions can be adjusted by loosening the jaw mounting bolts and changing the serration engaging position with the master jaws.

**Danger** Failure to follow the safety precautions below will result in death or serious injuries.

Use the T-nut in a state where it does not protrude from the master jaw circumference side end face.

- If not, the master jaws and T-nut may be damaged, causing the jaws and workpiece to fly out.

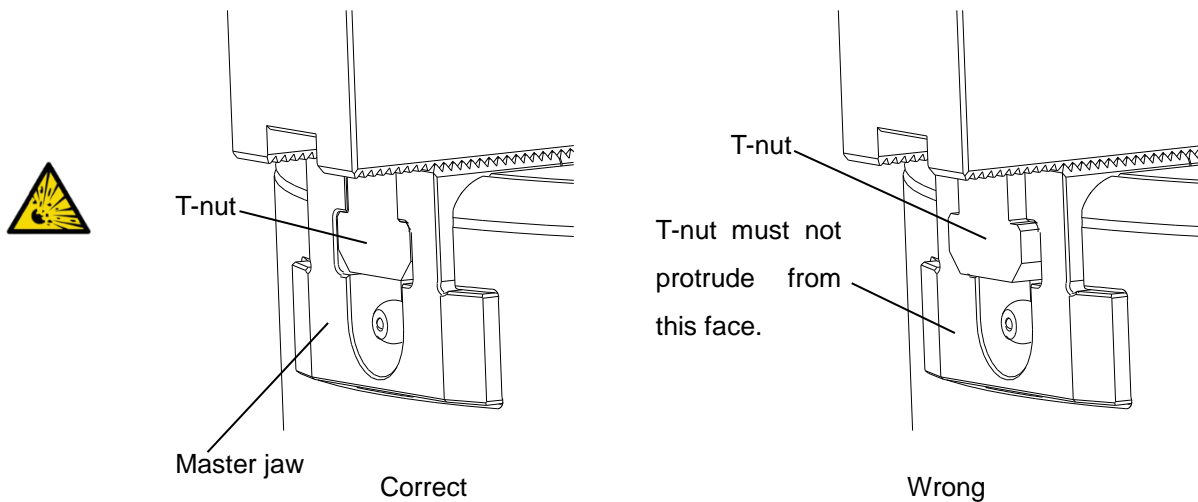

Figure 10

Do not use soft jaws as follows.

- ✓ Soft jaws manufactured by other companies
- ✓ With serration pitch different from that of master jaw
- ✓ Soft jaws joined by welding
- If serration engagement is faulty, the master jaws may be deformed and the gripping force is reduced, or the soft jaws may be damaged due to insufficient strength, causing the workpiece to fly out.

## Notice

Indicates instructions which, if you do not heed given instructions, could result in damage to the product or shortened service life, or damage to peripheral equipment.



When replacing the soft jaws, carefully clean fitting parts of the serration and the T-nuts.

- Insufficient cleaning will lead to an accuracy failure.



Set the hydraulic pressure according to the shape and cutting conditions of the workpiece.

- Clamping a pipe-shaped workpiece with a high gripping force may deform it.

## 4.2. Stroke mark

A stroke mark to check the jaw stroke position is stamped on the No. 1 jaw part on the body.

When the jaw is at the open end, the base line of the master jaw is aligned with the outer line of the full stroke range as shown in Figure 11.

The base line moves across the full stroke range when the jaw is opened / closed. However, the base line must be within the appropriate stroke range when the chuck grips a workpiece.

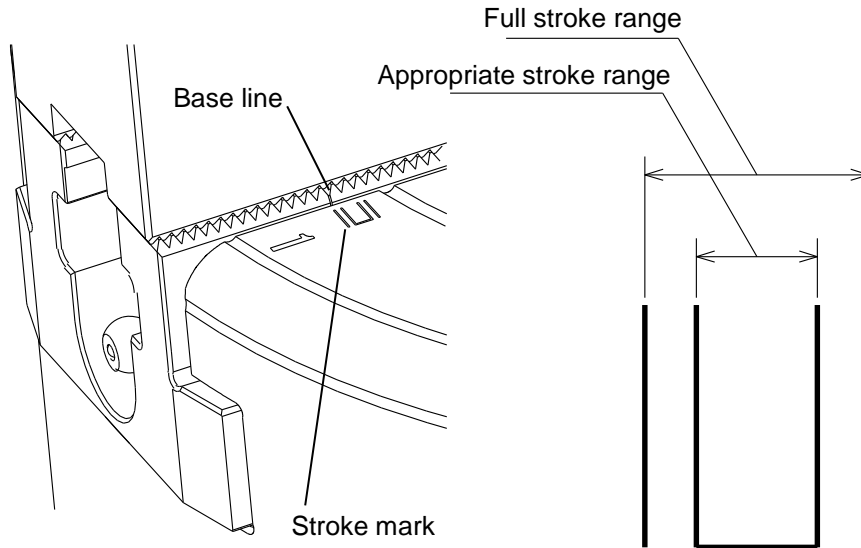

Figure 11 Stroke mark

Table 7

Type	BR06	BR08	BR10	BR12
Appropriate stroke range	1	2	2.3	2.7

(mm)



### Danger

Failure to follow the safety precautions below will result in death or serious injuries.

**When gripping a workpiece, the master jaw base line must be within the appropriate stroke range.**



- Gripping a workpiece near the stroke end may fail due to unevenness of the tolerance at the workpiece gripping part, causing the workpiece to fly out.
- Frequently gripping a workpiece near the stroke end will apply excessive force to the master jaws and lead to damage of the chuck, causing the workpiece to fly out.

**Before starting work, open and close the jaws without gripping a workpiece and confirm that the master jaw base line moves within the full stroke range.**



- If the jaw stroke becomes insufficient due to chips accumulating inside the chuck or loosened draw nut, the chuck may not grip the workpiece, causing the workpiece to fly out.

### 4.3. External Gripping Soft Jaw Forming Procedure

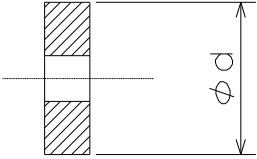
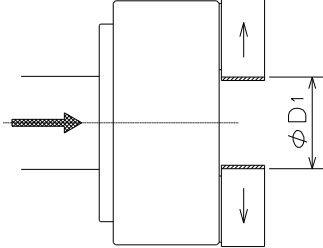
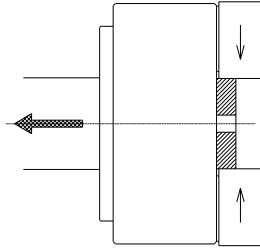
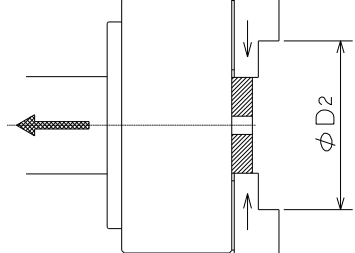
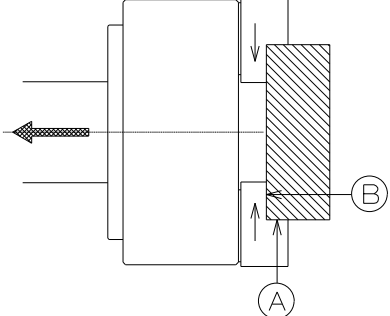
<p>① Preparation of disc for finish turning of top jaw</p> <p>The disc for finish turning of top jaw must have a thickness not to be distorted with the surface roughness of about 25 s.</p> <ul style="list-style-type: none"> <li>● It is convenient to prepare several types of discs with different outside diameters so as to use them properly according to the dimension of the forming part.</li> <li>● It is convenient to cut threads at the center in order to guide the disc using a bolt when gripping the disc.</li> </ul>	
<p>② Machining of disc gripping part</p> <p>Unclamp the chuck and open the jaws to the maximum.</p> <p>Next, machine <math>D_1</math>. <math>D_1</math> must be the dimension that can grip the disc near the center of the jaw stroke.</p> $D_1 = d + \frac{\text{jaw stroke}}{2}$	
<p>③ Gripping of disc</p> <p>Grip the disc at the <math>D_1</math> part.</p> <ul style="list-style-type: none"> <li>● Grip the disc while pressing against the chuck front face to prevent it from tilting. Stabilize the disc by gripping it several times.</li> <li>● Confirm that the master jaw base line is within the appropriate stroke range when the disc is gripped. (Refer to page 21.)</li> </ul>	
<p>④ Forming</p> <p>Machine <math>D_2</math> with the disc gripped.</p> <p><math>D_2</math> must be the same as the workpiece diameter (approx. H7) and the surface roughness must be 6.3 s or less.</p> <ul style="list-style-type: none"> <li>● Set the hydraulic pressure during forming to equal to or slightly higher than that during machining a workpiece.</li> <li>● If the disc becomes deformed, reduce the hydraulic pressure or change the disc shape to the one that is hardly deformed.</li> </ul>	
<p>⑤ Test cutting</p> <p>Remove the disc and grip a workpiece.</p> <ul style="list-style-type: none"> <li>● Confirm that the master jaw base line is within the appropriate stroke range when the workpiece is gripped. (Refer to page 21.)</li> <li>● Perform test cutting to confirm that the desired machining accuracy is obtained and no slip occurs.</li> <li>● Grip the workpiece so that it is brought into contact with the gripping surface A and B.</li> </ul>	

#### 4.4. Internal Gripping Soft Jaw Forming Procedure

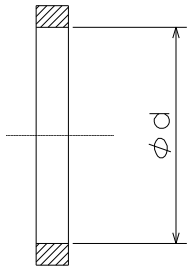
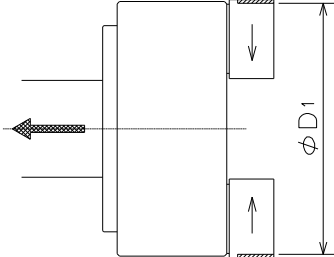
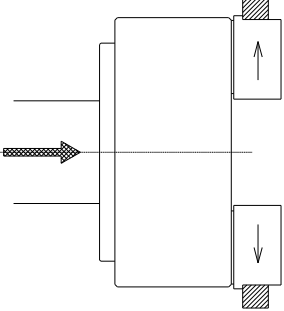
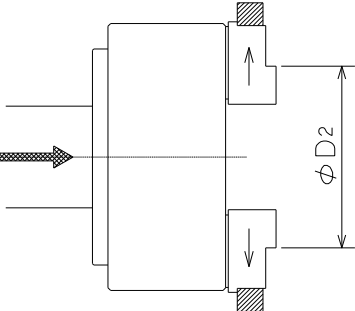
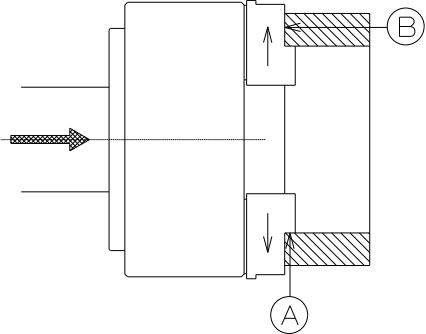
<p>① Preparation of ring for finish turning of top jaw</p> <p>The ring for finish turning of top jaw must have a thickness not to be distorted with the surface roughness of about 25 s.</p> <ul style="list-style-type: none"> <li>● It is convenient to prepare several types of rings with different inside diameters so as to use them properly according to the dimension of the forming part.</li> </ul>	
<p>② Machining of ring gripping part</p> <p>Unclamp the chuck and close the jaws to the minimum.</p> <p>Next, machine <math>D_1</math>. <math>D_1</math> must be the dimension that can grip the disc near the center of the jaw stroke.</p> $D_1 = d - \frac{\text{jaw stroke}}{2}$	
<p>③ Gripping of ring</p> <p>Grip the ring at the <math>D_1</math> part.</p> <ul style="list-style-type: none"> <li>● Grip the ring while pressing against the jaws to prevent it from tilting. Stabilize the ring by gripping it several times.</li> <li>● Confirm that the master jaw base line is within the appropriate stroke range when the ring is gripped. (Refer to page 21.)</li> </ul>	
<p>④ Forming</p> <p>Machine <math>D_2</math> with the ring gripped.</p> <p><math>D_2</math> must be the same as the workpiece diameter (approx. H7) and the surface roughness must be 6.3 s or less.</p> <ul style="list-style-type: none"> <li>● Set the hydraulic pressure during forming to equal to or slightly higher than that during machining a workpiece. For internal gripping, use the chuck with 1/2 or less of the max. permissible input force for external gripping.</li> <li>● If the ring becomes deformed, reduce the hydraulic pressure or change the ring shape to the one that is hardly deformed.</li> </ul>	
<p>⑤ Test cutting</p> <p>Remove the ring and grip a workpiece.</p> <ul style="list-style-type: none"> <li>● Confirm that the master jaw base line is within the appropriate stroke range when the workpiece is gripped. (Refer to page 21.)</li> <li>● Perform test cutting to confirm that the desired machining accuracy is obtained and no slip occurs.</li> <li>● Grip the workpiece so that it is brought into contact with the gripping surface A and B.</li> </ul>	



## 4.5. Tnut-Plus

A Tnut-Plus as shown in Figure 12-1 is provided for BR chucks as an option.

Soft jaws formed using the Tnut-Plus can maintain the gripping accuracy equivalent to just-formed soft jaws even after they are removed from the chuck once, because they can be reinstalled in the same positions.

- For corresponding Tnut-Plus types, refer to Table 4-1.
- To maintain the installation repeatability of the Tnut-Plus for a long period of time, always tighten the jaw mounting bolts from the chuck outside diameter side ① with the specified torque. (See Figure 12-2)
- The Tnut-Plus is elastically deformed when the bolts are tightened. Therefore, the resistance you feel when tightening the bolts is different from ordinary T-nuts, it is normal.
- If the Tnut-Plus is used for a long period of time, the soft jaws may be fixed and become hard to be removed. In this case, remove them by tapping with a plastic hammer. Apply CHUCK GREASE PRO to the side of the T-nut to stop it becoming fixed.
- The gripping accuracy may be deteriorated due to aging such as fatigue of the workpiece gripping surface. In such a case, re-form the soft jaws.

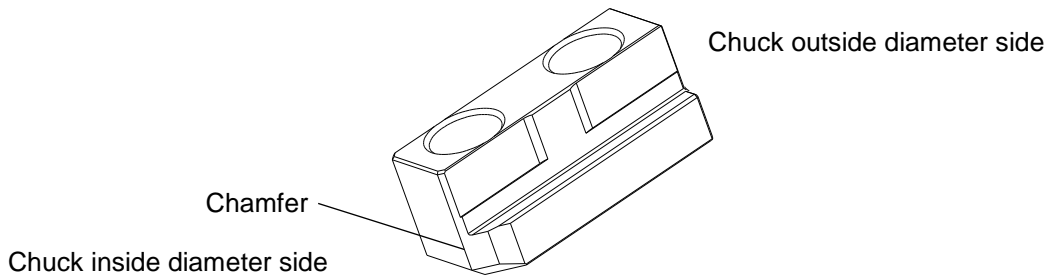

Figure 12-1 Tnut-Plus

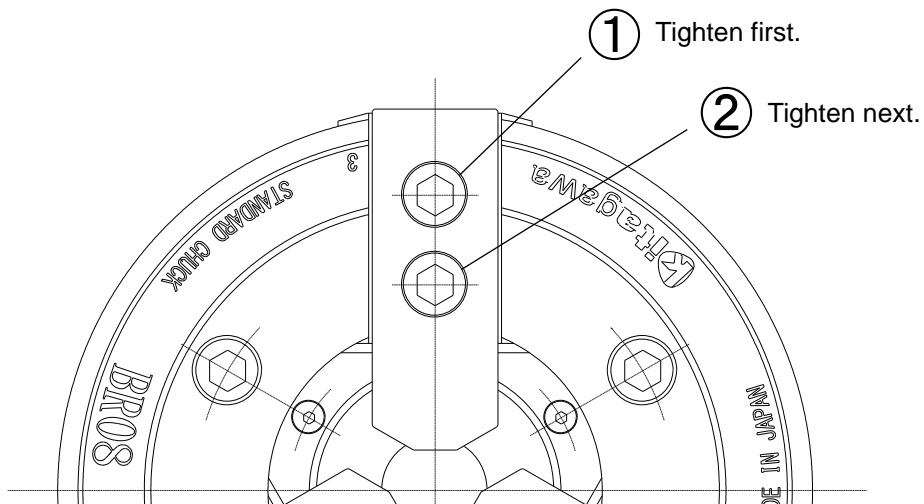

Figure 12-2 Tightening order of the jaw mounting bolts



## Warning

Failure to follow the safety precautions below could result in death or serious injuries.



**Mount the Tnut-Plus with the chamfer side facing the chuck inside diameter side. (See Figure 12-1)**

- If it is mounted in the opposite direction, seizure may occur due to significant deformation of the master jaws. As a result, the gripping force will be reduced, causing the workpiece to fly out.



**Do not use the Tnut-Plus on a chuck that does not correspond to it. (The T-slot shapes of such chucks do not match the Tnut-Plus, so the Tnut-Plus cannot be mounted physically. Do not use the Tnut-Plus forcedly on such chucks by additionally machining them.)**

- If the Tnut-Plus is used on such chucks, seizure may occur due to significant deformation of the master jaws. As a result, the gripping force will be reduced, causing the workpiece to fly out.
- Additional machining of the T-nut and master jaws may damage them, causing the workpiece to fly out.



**Do not use soft jaws manufactured by other companies.**

- If soft jaws manufactured by other companies are used, seizure may occur due to significant deformation of the master jaws. As a result, the gripping force will be reduced, causing the workpiece to fly out.
- Using soft jaws manufactured by other companies may damage the T-nut, causing the workpiece to fly out.

## Notice

Indicates instructions which, if you do not heed given instructions, could result in damage to the product or shortened service life, or damage to peripheral equipment.



Do not use soft jaws manufactured by other companies.

When mounting already-formed soft jaws again, use the same T-nut used when the soft jaws were formed, match the jaw No. of the soft jaws and master jaws, and mount the soft jaws in the same serration position. Also, carefully clean fitting parts of the serration and the T-nuts.

- Failure to follow the above precautions may lead to poor accuracy.

## 5. Additional Machining Allowable Range

When mounting a locator or jig on the body surface, add tapped holes and pin holes within the additional machining allowable range shown by the oblique line parts in Figure 13.

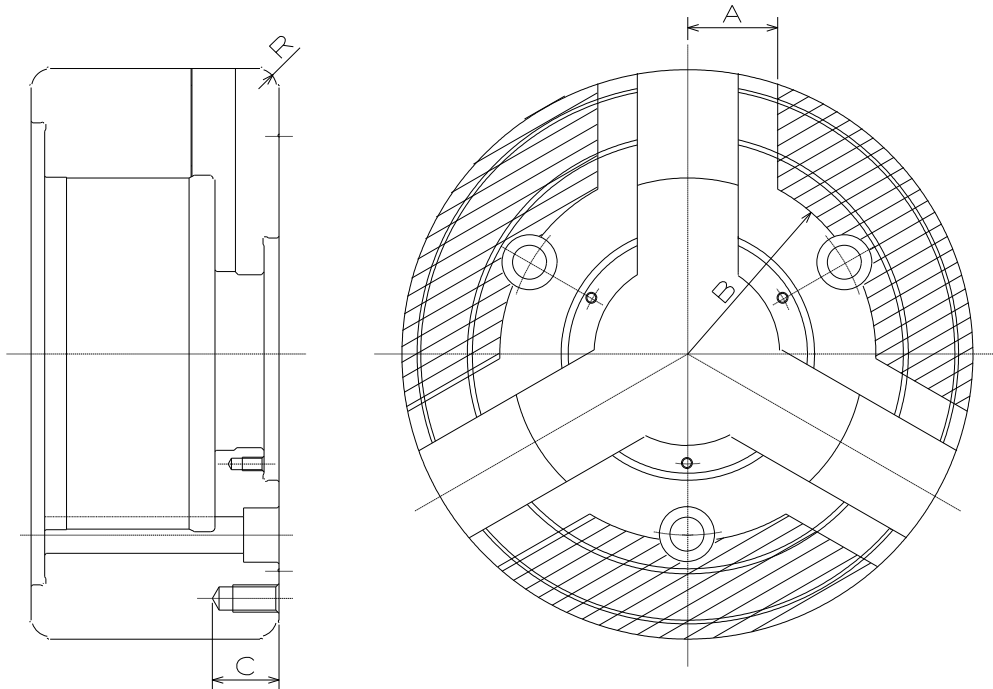

Figure 13 Additional machining allowable range

Table 8

Type	BR06	BR08	BR10	BR12
A	30	33	36	42
B	54.5	69	79.5	94.5
C (max)	25	25	25	30
R	5	7.5	7.5	11.5

(mm)

**Danger** Failure to follow the safety precautions below will result in death or serious injuries.



**Provide measures to prevent fly-out by centrifugal force (such as dowel pins) for the locator or jig. In addition, mount the locator or jig with enough bolts with sufficient strength.**

- Otherwise, the locator or jig may fly out due to centrifugal force.

## 6. Maintenance and Inspection

### 6.1. Periodic Inspection

Table 9 Periodic inspection

Interval	Contents
Every day	<ul style="list-style-type: none"> <li>● Supply grease. When using high speed rotation or a large quantity of water soluble coolant, shorten the greasing interval according to the operating conditions.</li> <li>● Before starting work, open and close the jaws without gripping a workpiece and confirm that the master jaw base line moves within the full stroke range. (Refer to page 21.)</li> <li>● Upon completion of the work, clean the chuck using an air gun.</li> </ul>
Every 3 months	<ul style="list-style-type: none"> <li>● Check the bolts of each part for looseness.</li> </ul>
Every 6 months or 100,000 strokes (Cast machining: every 2 months)	<ul style="list-style-type: none"> <li>● Disassemble and clean the chuck.(Refer to page 28.)</li> </ul>

### 6.2. Grease Supply

#### 6.2.1. Specified grease

Table 10 Specified grease

Type	Specified grease	Grease nipple	Grease amount per one point [g]
BR06	CHUCK GREASE PRO	JIS B 1575 : 2000 type 1 (M6×0.75)	4
BR08			6
BR10			10
BR12			12

#### 6.2.2. Greasing Procedure

- ① Open the jaws, and be sure to turn OFF the main power of the machine before starting the work.
- ② Supply the amount of grease shown in Table 10 from the grease nipple of each master jaw using a grease gun.
- ③ After supplying the grease, open and close the jaws several times without gripping the workpiece.

#### 6.2.3. Safety Information on Grease and Antirust Oil

##### Applicable range

- Specified grease
- Antirust agent applied to the product at the delivery

For the grease other than the specified one and antirust oil prepared by the customer, refer to the safety data sheet (SDS) prepared for respective oils.

Table 11 First-aid treatment

Aspiration	In case of much aspiration, go to a place where there is fresh air, and cover your body with a blanket to keep your body warm. Consult a doctor if necessary.
Sticking to your skin	Wipe off the oil, and wash your skin with water and soap. If you feel itchy or you get inflamed, consult a doctor immediately.
Entering your eye	Wash your eye with fresh water for at least 15 minutes, and then consult a doctor.
Accidental drinking	Consult a doctor immediately without vomiting forcibly.

### 6.3. Disassembly

Read the following disassembling procedure referring to page 5 and 6.

- ① Before start of work, be sure to turn off the main power of the machine.
  - ② Loosen the jaw mounting bolts [12] and remove the soft jaws [4] and T-nuts [5].
  - ③ Loosen the cover mounting bolts [14] and remove the cover [8].
  - ④ Loosen the chuck mounting bolts [11] and rotate the draw nut [7] using the draw nut plate wrench [10].  
Then, remove the chuck from the spindle.
  - ⑤ Remove the wedge plunger [2] toward the rear of the chuck.
  - ⑥ Remove the master jaws [3] toward the inner circumference of the chuck.
- Reassemble the product through reverse procedure of disassembly while applying the specified grease sufficiently.
  - When reinstalling the chuck to the machine, refer to "8.5 Chuck Installation Procedure".
  - After reassembly, it is recommended to confirm that the specified gripping force is obtained according to the procedure on page 12.

 **Danger** Failure to follow the safety precautions below will result in death or serious injuries.

 **Clean the disassembled parts with kerosene, carefully check them for damage, wear, crack, or seizure, and repair or replace them if necessary.**

- Continuous use of faulty parts may damage the chuck, causing the workpiece to fly out.

**Notice** Indicates instructions which, if you do not heed given instructions, could result in damage to the product or shortened service life, or damage to peripheral equipment.

 Reassemble the parts with the jaw numbers marked on the body, wedge plunger, and master jaws matched respectively.

Also, do not hit the parts each other or give a shock to them. Be especially careful not to hit the body when installing the master jaw.

- Failure to observe the precautions may result in accuracy failure.

## 7. Troubleshooting

### 7.1. Troubleshooting

If a failure is suspected, check the contents in Table 12 again and take necessary measures.

Table 12 Troubleshooting

Problem	Cause	Countermeasure
Jaws do not move	Parts are damaged	Disassemble and clean the chuck. Replace damaged parts. (Refer to page 28.)
	Slideways get seized	Disassemble and clean the chuck. Correct the seized part with an oilstone or replace the part. (Refer to page 28.)
	Cylinder does not operate	Check the piping and electric system, and if normal, repair or replace the cylinder.
Stroke is insufficient	Chips accumulate inside	Disassemble and clean the chuck. (Refer to page 28.)
	Draw pipe loosened	Remove the draw pipe from the cylinder and retighten it.
Workpiece slips	Jaw stroke insufficient	Confirm that the master jaw base line is within the appropriate stroke range when a workpiece is gripped. (Refer to page 21.)
	Lack of gripping force	Confirm that the hydraulic pressure is appropriate.
	The formed diameter of the top jaw does not match the workpiece diameter	Re-form the jaw according to the correct forming method. (Refer to "4. Soft Jaw")
	Excessive cutting force	Calculate cutting force and check that it is appropriate for the chuck and machine specifications.
	Lack of grease	Supply grease. (Refer to page 27.)
	Excessive rotational speed	Slow down the rotational speed to obtain required gripping force.
	Swing due to misalignment of the bar feeder, steady rest, tailstock, etc.	Thoroughly conduct alignment to eliminate swing.
Accuracy failure	Run-out of chuck circumference is large	Adjust the run-out to 0.020 mm T.I.R. or less.
	Dust accumulates in serration parts of master jaw and top jaw	Remove the top jaws and thoroughly clean the serration parts.
	Jaw mounting bolts are not sufficiently tightened	Tighten the jaw mounting bolts with the specified torque. (Refer to page 8.)
	Top jaw forming method is improper	Confirm that the disc for finish turning of top jaw is parallel to the chuck end face and it is not deformed by the gripping force.

	Due to excessive top jaw height, top jaws are deformed and jaw mounting bolts are extended	Lower the top jaw height. Adjust the top jaws so that the gripping surfaces contact the workpiece evenly.
	Excessive gripping force deforms workpiece.	Reduce the gripping force to the extent that machining can be executed to prevent deformation.



## Danger

Failure to follow the safety precautions below will result in death or serious injuries.



**In case that the chuck failed to operate due to a seizure or breakage, remove the chuck from the machine following the disassembly procedure on page 28. When the top jaws and covers cannot be removed due to a blockage of workpiece, do not disassemble forcibly but please contact us or our agent.**

- Forcible disassembly could cause serious human accidents.



**The chuck must be repaired only by skilled persons who have received the training course.**

- Repair by unskilled persons or persons other than us or our agents could cause serious human accidents.

## 7.2. Contact Information In Case Problem Occurs

Please get in touch with our sales agent from which you purchased the chuck or our office of the address given on the back cover when the chuck fails.

## For Machine Manufacturers

The sections starting from this page provide explanations for machine manufacturers (who mount the chuck on machines).

Not only machine manufacturers but also persons who attach/detach the chuck are to read and thoroughly understand the contents so as to perform safety work.

## 8. Installation

### 8.1. Installation Conceptual Diagram

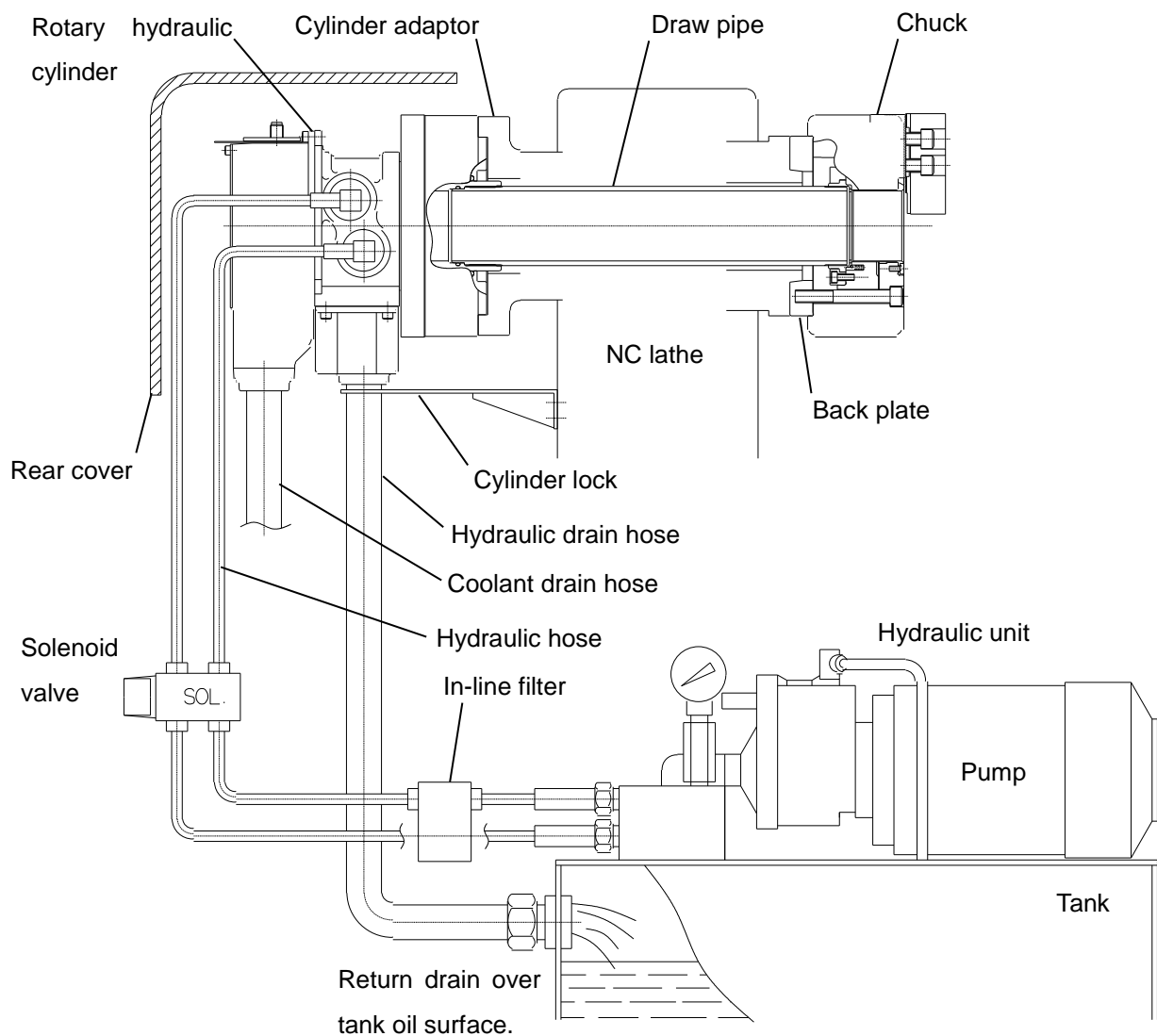

Figure 14 Installation conceptual diagram





## Danger

Failure to follow the safety precautions below will result in death or serious injuries.



**Confirm that the cylinder does not cause pressure drop during machining beforehand when operating other actuators together with the cylinder using the same hydraulic source.**

- Reduction of hydraulic pressure will reduce the gripping force, causing the workpiece to fly out.



**Provide the drain hose so that drain flows smoothly without stagnation.**

**The drain must be returned over the oil surface in the hydraulic unit to prevent back pressure.**

- If drain does not flow smoothly, the cylinder may cause oil leakage, resulting in fire.



**For the cylinder and other peripheral devices, follow their respective instruction manuals.**

- If not, serious human accidents may occur.



## Warning

Failure to follow the safety precautions below could result in death or serious injuries.



**Eliminate dust in the hydraulic circuit completely. In addition, incorporate an in-line filter.**

- If foreign substances enter the cylinder, the rotary valve may get seized and the cylinder may rotate while tearing the hose. Moreover, the hydraulic pressure may be blocked, causing the workpiece to fly out.



**Use a flexible hose to prevent bending stress and tension from being applied to the cylinder.**

- If the cylinder is rotated with an external force applied to it, the cylinder rotary valve may get seized and the cylinder may rotate while tearing the hose. Moreover, the hydraulic pressure may be blocked, causing the workpiece to fly out.

## Notice

Indicates instructions which, if you do not heed given instructions, could result in damage to the product or shortened service life, or damage to peripheral equipment.



Especially when using a large hydraulic unit, insert a throttling valve in the pressure supply line to restrict surge pressure.

- An excessive surge will shorten the chuck service life.



Use a hydraulic hose with the inside diameter as large as possible and with a piping length as short as possible.

- If the inner diameter is too small or the piping length is too long, the jaw opening/closing speed may become slow.



Provide the drain hose with a slight flow gradient to avoid any air pocket.

- If air is mixed in drain, noise caused by the hydraulic unit may increase or the service life of the hydraulic unit may be shorten.

## 8.2. Back plate

Prepare a back plate corresponding to the spindle end shape and chuck mounting dimensions.

The chuck mounting dimensions conform to JIS B 6109-2: 2005.

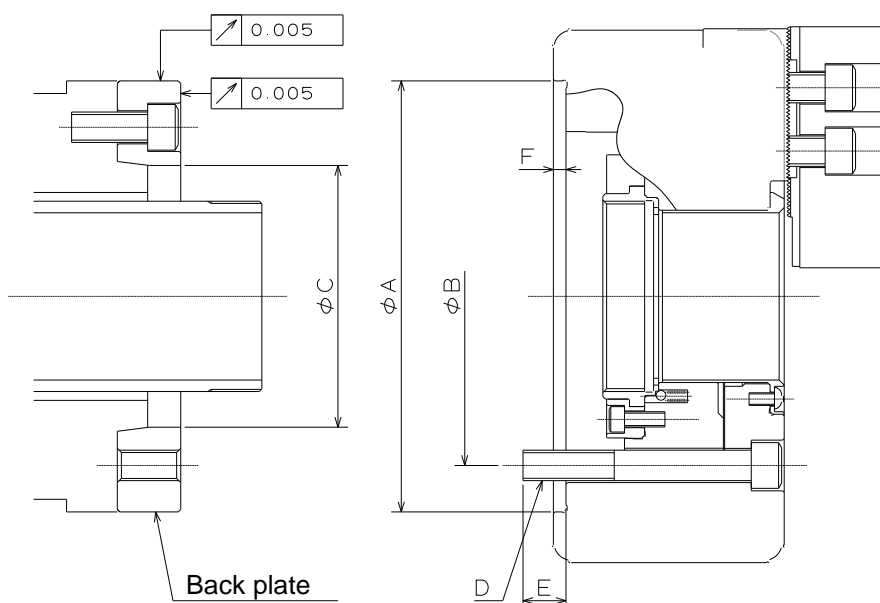

Figure 15 Mounting dimensions

Table 13

Type	BR06	BR08	BR10	BR12
A (H6)	140	170	220	300
B	104.8	133.4	171.1	235
C (max)	82	104	137	155
D	3xM10	3xM12	3xM16	3xM20
E	16	17	22	29
F	5	5	5	6

(mm)

### Notice

Indicates instructions which, if you do not heed given instructions, could result in damage to the product or shortened service life, or damage to peripheral equipment.



The end face run-out and fitting diameter run-out of the back plate must be 0.005 mm T.I.R. or less, respectively. (It is also allowed to mount the back plate on the machine and finish the end face and fitting diameter in this state.)

- Excessive back plate run-out may result in accuracy failure.



Dimension C must be equal to or less than the value in Table 13 so that the plunger stroke is restricted by the back plate.

- If the plunger stroke is not restricted, the master jaws may interfere with the cover and be damaged when the chuck is combined with a cylinder having a stroke longer than the chuck specifications.

### 8.3. Draw Pipe

Determine the draw pipe length L according to the distance X between the chuck mounting face and cylinder mounting face. Whether sufficient strength is obtained with respect to the operating conditions must be judged by the designer of the draw pipe. The dimensions provided in this manual do not guarantee that the draw pipe will not be damaged under every condition.

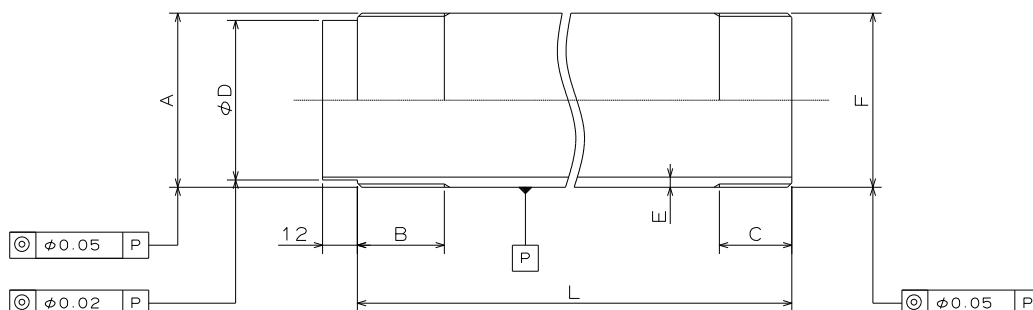

Figure 16 Draw pipe

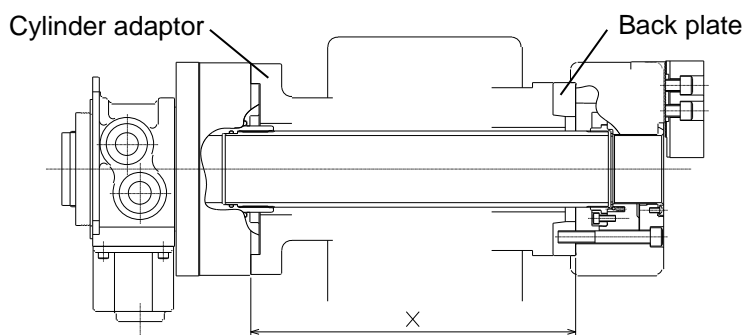

Figure 17 Distance between chuck mounting face and cylinder mounting face

Table 14 Draw pipe dimensions

Type	Cylinder	A	B	C	D (f7)	E (min)	F (max)	L
BR06	SR1453 SS1453K	M60x2	30	20	55	3.5	M60x2	X+36
BR08	SR1566 SS1666K	M75x2	35	25	70	4.5	M75x2	X+44
BR10	SR1781 SS1881K	M90x2	35	25	85	4.5	M90x2	X+41
BR12	SR2010 SS2110K	M115x2	35	30	110	4.5	M115x2	X+40

(mm)

#### Notice

Indicates instructions which, if you do not heed given instructions, could result in damage to the product or shortened service life, or damage to peripheral equipment.



Do not connect Cylinder and Chuck by connecting multiple draw pipes.

- Failure to follow the above precautions may lead to poor accuracy.

## 8.4. Disassembly of Draw Nut and Threading

Read the following procedure referring to page 5 and 6.

- ① Loosen the plunger mounting bolts [13] and remove the plunger nut [6] and draw nut [7].  
At this time, be careful not to lose the steel ball [15] and coil spring [9].
- ② Cut threads in the draw nut [7] corresponding to the draw pipe thread diameter.
- ③ Assemble the draw nut [7] in the plunger nut [6], and tighten the plunger nut mounting bolts [13].



### **Danger**

Failure to follow the safety precautions below will result in death or serious injuries.



**Do not cut threads exceeding the dimension F in Table 14 in the draw nut.**

**The thread accuracy must be 6H / 6g.**

- If not, the draw nut is damaged due to its insufficient strength and the gripping force is lost instantaneously, causing the workpiece to fly out.

## 8.5. Chuck Installation Procedure

For the cylinder mounting procedure, also read the instruction manual of the cylinder.

- ① Before start of work, be sure to turn off the main power of the machine.
- ② Apply adhesive to the thread part of the draw pipe and screw the draw pipe in the cylinder piston rod.  
For the tightening torque to be applied at this time, refer to “2.Important Safety Precautions” on the instruction manual of the cylinder.
- ③ Install the cylinder on the spindle.
- ④ Check the run-out of the cylinder. If normal, connect the hydraulic hose and the drain hose.
- ⑤ Turn on the machine power, and operate the cylinder several times at 0.5 MPa. If it is normal, move the piston to the forward end and turn off the machine main power.
- ⑥ Remove the soft jaws and cover of the chuck.
- ⑦ Insert the draw nut plate wrench into the chuck center hole, and connect the draw nut to the draw pipe while rotating the draw nut. If it cannot be screwed in smoothly, do not screw forcibly and check the thread for inclination.
- ⑧ Rotate the draw nut until the chuck is completely fitted to the spindle installation surface.
- ⑨ Tighten the chuck mounting bolts evenly with the specified torque. (See “2.Important Safety Precautions”) The chuck circumference run-out must be 0.020 mm T.I.R or less. When performing centering adjustment, tap the body side face with a plastic hammer.
- ⑩ Rotate the draw nut until the master jaw base line is aligned with the outer line of the stroke mark. (Refer to page 21.)  
A click stop (locking mechanism) is provided for the draw nut. Finish the adjustment at a position where you feel it click.
- ⑪ Operate the cylinder at 0.5 MPa and confirm that the master jaw base line moves within the full stroke range. (Refer to page 21.)

- ⑫ If the chuck or cylinder is replaced from another type, calculate and change the hydraulic pressure to obtain the same gripping force as the previous chuck. (Refer to “3.2. Calculation of Operating Condition”.)



## Warning

Failure to follow the safety precautions below could result in death or serious injuries.



**If the chuck or cylinder is replaced from another type, calculate and change the hydraulic pressure to obtain the same gripping force as the previous chuck. (Refer to “3.2. Calculation of Operating Condition”.)**

- Insufficient gripping force may cause the workpiece to fly out.
- Especially, when replacing from the BB200 series, it is necessary to increase the oil pressure to obtain the same gripping force as before.

## 9. Others

### 9.1. Standard or Directive to Conform

This product conforms to the following EN standards and EU directive:

- Machinery Directive:2006/42/EC Annex I
- EN ISO 12100:2010
- EN1550:1997+A1:2008

## 9.2. Marking of Product

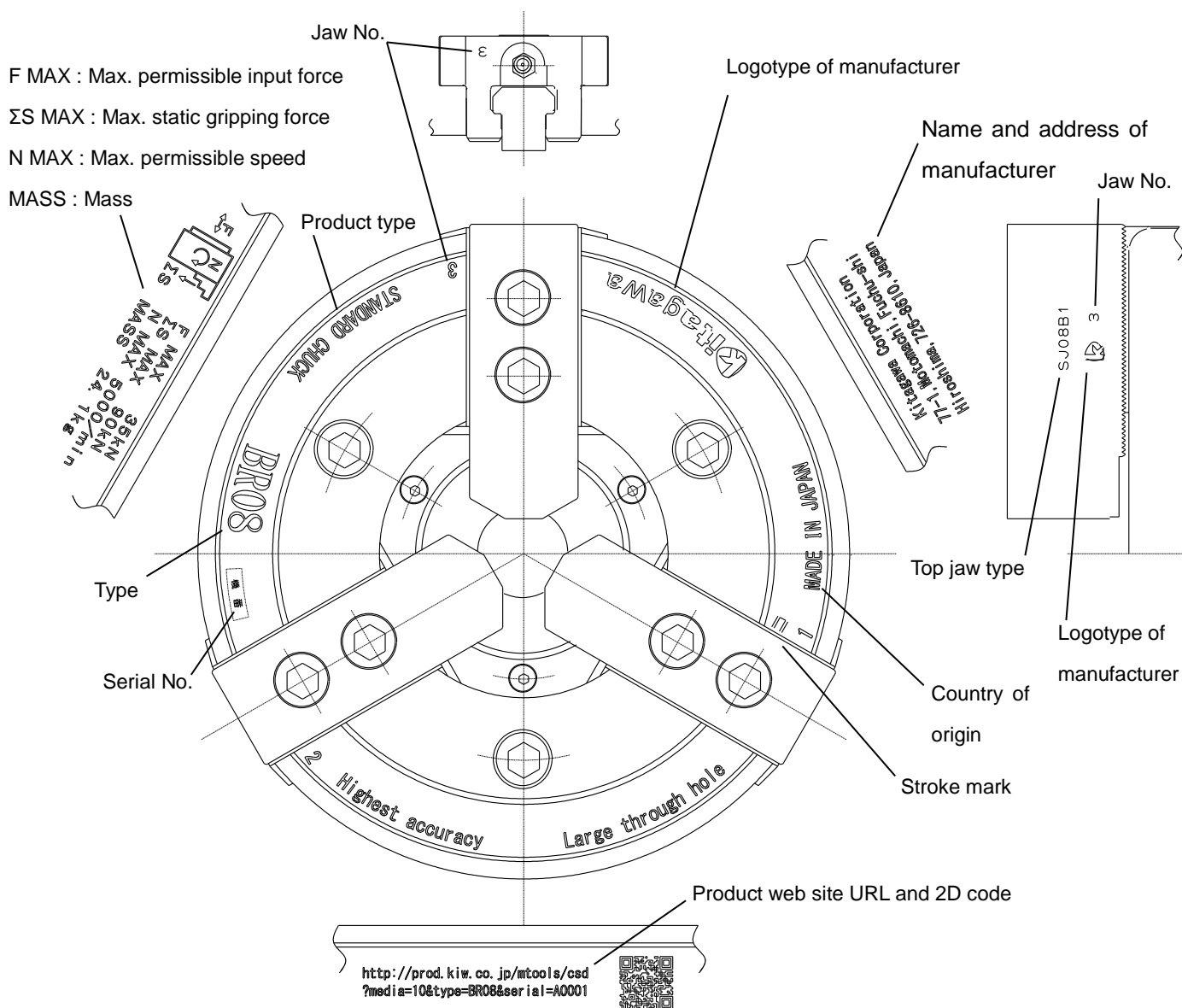

Figure 18 Marking

The mass stamped on the chuck is the value when the standard back plate is included.

Table 15

Type	BR06	BR08	BR10	BR12
Back plate	A <sub>2</sub> -5	A <sub>2</sub> -6	A <sub>2</sub> -6	A <sub>2</sub> -6
Spindle end shape	A <sub>2</sub> -5	A <sub>2</sub> -6	A <sub>2</sub> -6	A <sub>2</sub> -6
Stamp	13.8 kg	24.1 kg	40.9 kg	76.5 kg

### 9.3. Disposal

Dispose of this unit in accordance with the laws and regulations of your country.

## **COPY of Original declaration of incorporation**

of partly completed machinery

in accordance with the EC Machinery Directive 2006/42/EC Annex II part 1.B

We hereby declare that the following product conform with the essential health and safety requirements of the EC Machinery Directive so that the product is to be incorporated into end-machinery. The product must not be put into service until end-machinery has been declared in conformity with the provisions of the EC Machinery Directive 2006/42/EC Annex II part 1.A.

We also declare that the specific technical documentation for this partly completed machinery was drawn up according to the EC Machinery Directive 2006/42/EC Annex VII part B. We engage to transmit the specific technical documentation to the market surveillance authorities on their justified request through the person authorized to compile the documentation in our company.

Product : Standard chuck

Model : BR series  
(Models BR06, BR08, BR10, BR12)

Serial number : See original declaration

Authorized complier : Mark Jones / Financial Director  
in the community UNIT 1 THE HEADLANS, DOWNTON,  
SALISBURY, WILTSHIRE, SP5 3JJ, UNITED  
KINGDOM

The essential health and safety requirements in accordance with the EC Machinery Directive 2006/42/EC Annex I were applied and fulfilled:  
1.1.2, 1.1.3, 1.1.5, 1.1.6, 1.3.1, 1.3.2, 1.3.4, 1.5.4, 1.5.8, 1.5.9, 1.5.13, 1.6.1, 1.7.1, 1.7.2, 1.7.3, 1.7.4, 1.7.4.1, 1.7.4.2

The following harmonized standards were applied:  
EN ISO 12100:2010, EN 1550:1997+A1: 2008

Signature : See original declaration

Place / Date : See original declaration

Name / Title : Tamio Nishimiya / Manager, Development section  
Technical department  
Kitagawa Global hand Company

Being the responsible person appointed and employed the manufacturer.



**株式会社 北川鉄工所 キタガワグローバルハンドカンパニー**

Kitagawa Corporation Kitagawa Global hand Company

本社 広島県府中市元町 77-1

〒726-8610

TEL(0847)40-0561

FAX(0847)45-8911

77-1 Motomachi Fuchu-shi, Hiroshima-pref.,726-8610,Japan

TEL+81-847-40-0561

FAX+81-847-45-8911

**■国内**

東京営業課	埼玉県さいたま市北区吉野町 1-405-1	〒331-9634	TEL ( 048 ) 667-3469	FAX( 048 ) 663-4678
仙台支店駐在	宮城県仙台市若林区大和町 4-15-13	〒984-0042	TEL ( 022 ) 232-6732 ( 代 )	FAX( 022 ) 232-6739
名古屋営業課	愛知県名古屋市中川区上高畑 2-62	〒454-0873	TEL ( 052 ) 363-0371 ( 代 )	FAX( 052 ) 362-0690
大阪営業課	大阪府大阪市住之江区北加賀屋 3-2-9	〒559-0011	TEL ( 06 ) 6685-9065 ( 代 )	FAX( 06 ) 6684-2025
広島営業課	広島県府中市元町 77-1	〒726-8610	TEL ( 0847 ) 40-0541	FAX( 0847 ) 46-1721
九州支店駐在	福岡県福岡市博多区板付 7-6-39	〒812-0888	TEL ( 092 ) 501-2102 ( 代 )	FAX( 092 ) 501-2103
海外営業課	広島県府中市元町 77-1	〒726-8610	TEL ( 0847 ) 40-0526	FAX( 0847 ) 45-8911

**■海外**

America Contact	<b>KITAGAWA-NORTHTECH INC.</b> <a href="http://www.kitagawa.us">http://www.kitagawa.us</a> 301 E. Commerce Dr, Schaumburg, IL. 60173 USA <b>TEL +1 847-310-8787 FAX +1 847-310-9484</b>
	<b>TECNARA TOOLING SYSTEMS, INC.</b> <a href="http://www.tecnaratools.com">http://www.tecnaratools.com</a> 12535 McCann Dr, Santa Fe Springs, California 90670 USA <b>TEL +1 562-941-2000 FAX +1 562-946-0506</b>
Europe Contact	<b>KITAGAWA EUROPE LTD.</b> <a href="http://www.kitagawa.global/en">http://www.kitagawa.global/en</a> Unit 1 The Headlands, Downton, Salisbury, Wiltshire SP5 3JJ, United Kingdom <b>TEL +44 1725-514000 FAX +44 1725-514001</b>
	<b>KITAGAWA EUROPE GmbH</b> <a href="http://www.kitagawa.global/de">http://www.kitagawa.global/de</a> Borsigstrasse 3, 40880,Ratingen Germany <b>TEL +49 2102-123-78-00 FAX +49 2102-123-78-69</b>
	<b>KITAGAWA EUROPE GmbH Poland Office</b> <a href="http://www.kitagawa.global/pl">http://www.kitagawa.global/pl</a> 44-240 Zory, ul. Niepodleglosci 3 Poland <b>TEL +48 607-39-8855 FAX +48 32-749-5918</b>
	<b>KITAGAWA EUROPE GmbH Czech Office</b> <a href="http://www.kitagawa.global/cz">http://www.kitagawa.global/cz</a> Purkynova 125 621 00 Brno, Czech Republic <b>TEL +420 549-273-246 FAX +420 549-273-246</b>
	<b>KITAGAWA EUROPE GmbH Romania Office</b> <a href="http://www.kitagawa.global/ro">http://www.kitagawa.global/ro</a> Strada Heliului 15, Bucharest 1 , 013991, Romania <b>TEL +40 727-770-329</b>
	<b>KITAGAWA EUROPE GmbH Hungary Office</b> <a href="http://www.kitagawa.global/hu">http://www.kitagawa.global/hu</a> Dery T.u.5 , H-9024 Győr, Hungary <b>TEL +36 30-510-3550</b>
Asia Contact	<b>KITAGAWA INDIA PVT LTD.</b> <a href="http://www.kitagawa.global/in">http://www.kitagawa.global/in</a> Plot No 42, 2nd Phase Jigani Industrial Area, Jigani, Bangalore – 560105, Karnataka, India. <b>TEL +91-80-2976-5200 FAX +91-80-2976-5205</b>
	<b>KITAGAWA (THAILAND) CO., LTD. Bangkok Branch</b> 9th FL, Home Place Office Building, 283/43 Sukhumvit 55Rd. (Thonglor 13),Klongton-Nua, Wattana, Bangkok 10110, Thailand <b>TEL +66 2-712-7479 FAX +66 2-712-7481</b>
	<b>KITAGAWA IRON WORKS (SHANGHAI) CO., LTD.</b> Room308 3F Building B. Far East International Plaza,No.317 Xian Xia Road, Chang Ning, Shanghai, 200051China <b>TEL +86 21-6295-5772 FAX +86 21-6295-5792</b>
	<b>KITAGAWA IRON WORKS (SHANGHAI) CO., LTD. Guangzhou Office</b> B07,25/F,West Tower,Yangcheng International Trading Centre,No.122,EastTiyu Road,Tianhe District,Guangzhou, China <b>TEL+86 20-2885-5276</b>
	<b>DEAMARK LIMITED</b> <a href="http://www.deamark.com.tw">http://www.deamark.com.tw</a> No. 6, Lane 5, Lin Sen North Road, Taipei, Taiwan <b>TEL +886 2-2393-1221 FAX +886 2-2395-1231</b>
Oceania Contact	<b>KITAGAWA KOREA AGENT CO., LTD.</b> <a href="http://www.kitagawa.co.kr">http://www.kitagawa.co.kr</a> 803 Ho, B-Dong, Woolim Lion's Valley, 371-28 Gasan-Dong,Gumcheon-Gu, Seoul, Korea <b>TEL +82 2-2026-2222 FAX +82 2-2026-2113</b>
	<b>DIMAC TOOLING PTY. LTD.</b> <a href="http://www.dimac.com.au">http://www.dimac.com.au</a> 69-71 Williams Rd, Dandenong South, Victoria, 3175 Australia <b>TEL +61 3-9561-6155 FAX +61 3-9561-6705</b>

本取扱説明書記載の商品は「外国為替及び外国貿易法」の「輸出貿易管理令」及び「外国為替令」の規制対象貨物です。同法に基づき、

経済産業省大臣による輸出許可が必要となる場合がございます。日本国外へ持ち出される場合は、あらかじめ当社にご相談ください。

The products herein are controlled under Japanese Foreign Exchange and Foreign Trade Control Act. In the event of importing and/or exporting the products, you are obliged to consult KITAGAWA as well as your government for the related regulation prior to any transaction.

2019.12.