

450

venturion

The premium presetting and measuring machine for tools of all kinds



ZOLLER
expect great measures®

venturion
450

Opening Up New Perspectives

The ZOLLER »venturion 450« allows multiple options for fast and safe data transfer to the machine tool while ensuring data integrity. With networked manufacturing you can manage all tool data from a central location — this is integral to the networked manufacturing environment of the future.

With its intuitive operation, precise measuring results, and effortless integration, the »venturion 450« offers everything you need for measuring and presetting of all tools types. Ergonomics and a long machine life are hallmarks of the »venturion 450« because it's manufactured exclusively from high-quality brand name components. It is also suitable for operation on the shop floor, directly beside the CNC machine.

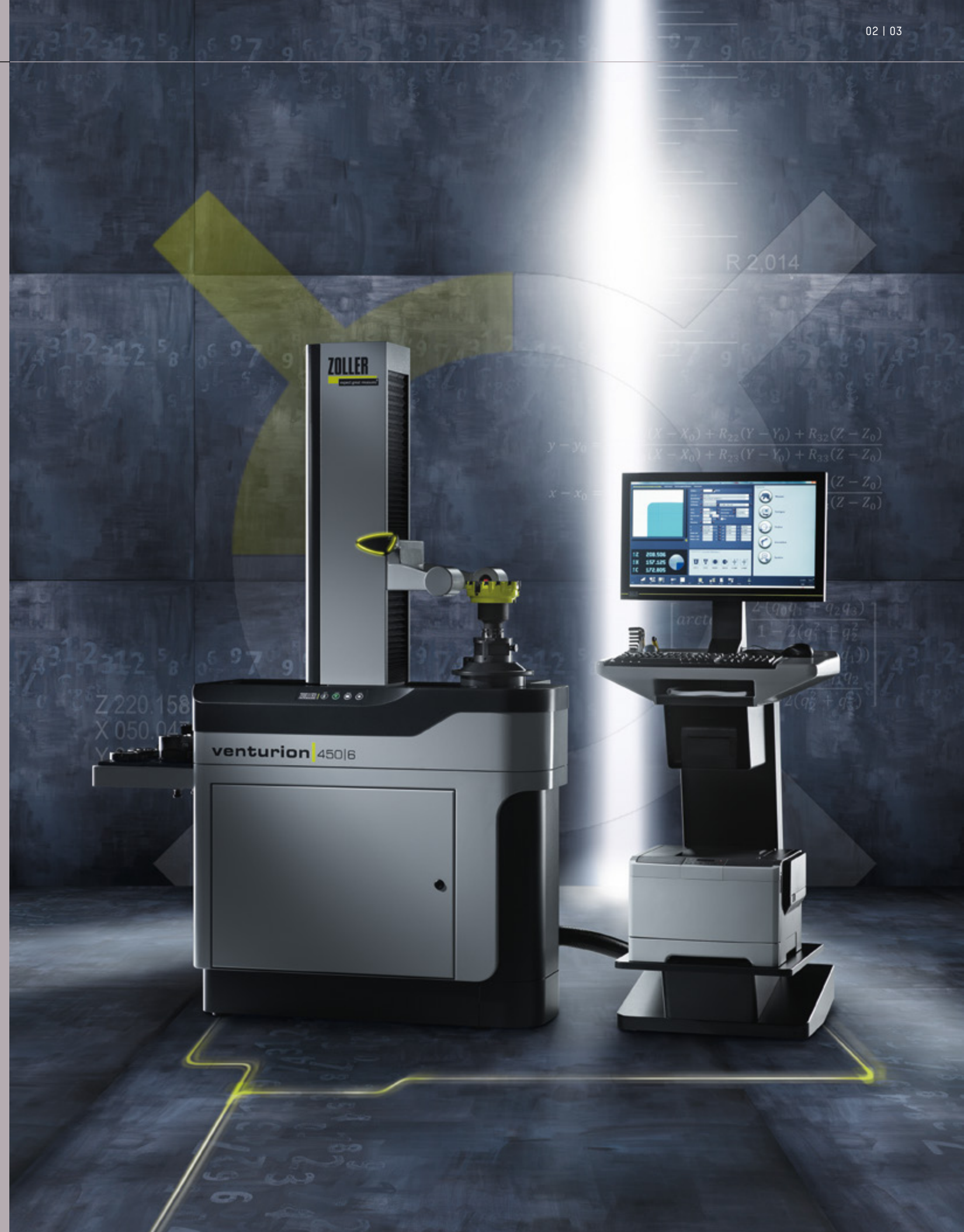

venturion
450

Ready for Smart Manufacturing

Measuring tools is just the beginning. Exchanging data seamlessly throughout the manufacturing plant with μm -precision — that is a decisive step toward networked manufacturing, and a step into the future that you will take easily with the ZOLLER »venturion«.

The ZOLLER »venturion« can transmit data safely to a variety of systems regardless of the machine manufacturer, via label, RFID chip, post-processor, DataMatrix code, or production control systems. No matter what new system is in demand in the future, ZOLLER can integrate it.



venturion
450

Dynamic crosshair

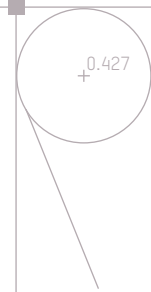

Clear entry dialog

Measurements at the push of a button

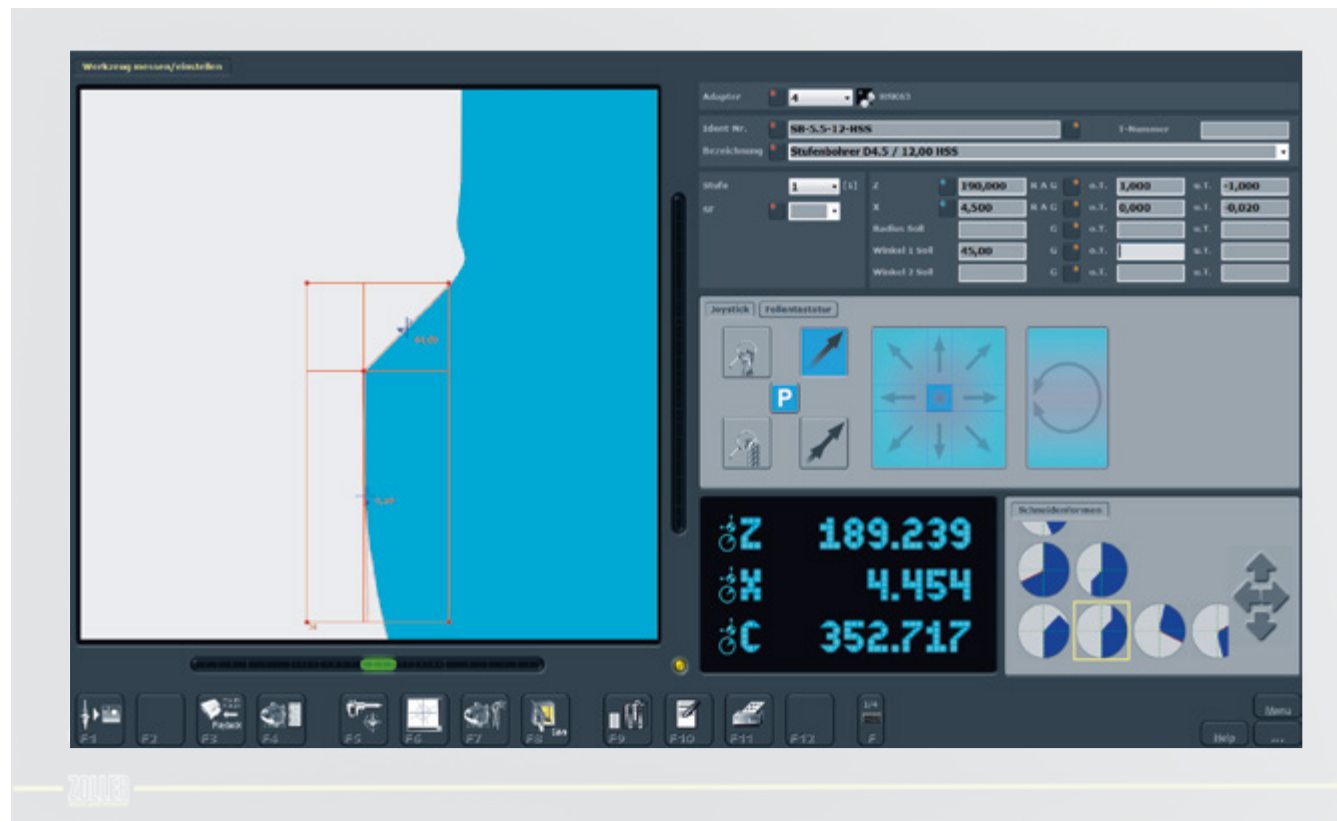

Automatic
Cutting edge shape detection

Virtual joystick

Navigate the Road to Success



So simple that even complex measurements are successful from day one. So comprehensive, that there is a solution for every requirement. It is not without reason that »pilot 3.0« operating technology is considered the unrivaled standard for tool measurement worldwide.

From presetting, measuring, and inspecting to tool management — ZOLLER »venturion« with »pilot 3.0« brings more efficiency to tool management. Due to its modular structure, it can be adapted to new requirements at any time. Self-explanatory graphic menu buttons guarantee reliable navigation to the destination. Successful measuring is as easy as that.

venturion
450

Inner Qualities that You Can See

There are many reasons for the unique precision of ZOLLER »venturion«, and most of them can only be seen by looking inside. There you will find Heidenhain measuring systems, Festo pneumatics, and Uhing drives, yet there are a number of high-quality components to discover on the outside, too. Take the CCD camera with coated lenses and special ZOLLER LED optics for standard cutting inspection in incident light — or the specially alloyed, thermally optimized base, ensuring robust usability for the shop floor. Put all these together and you have a presetting and measuring machine that is unrivaled in terms of precision and longevity.

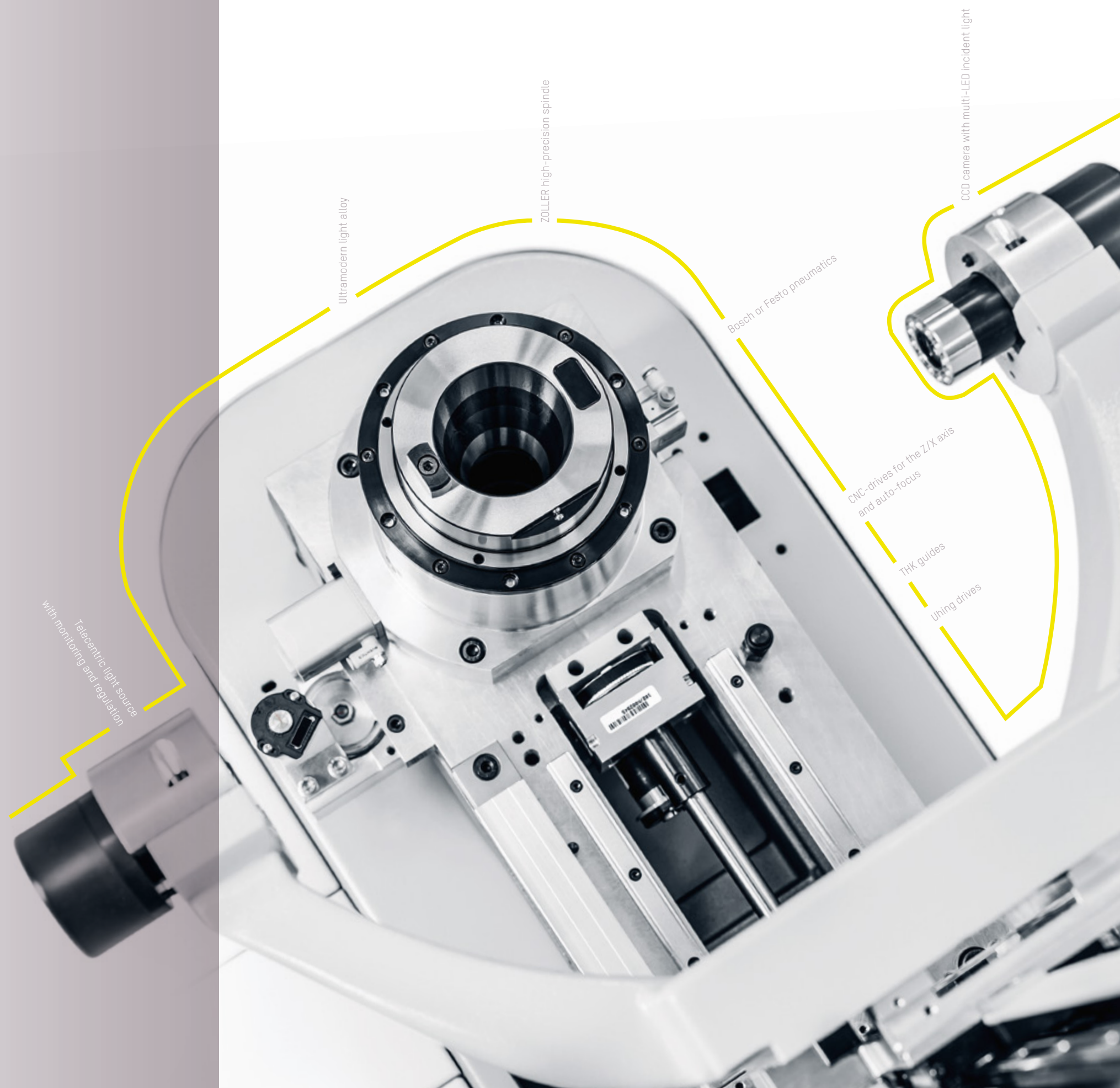

venturion
450

Make Your Workplace a Comfort Zone

We paid particular attention to ergonomics in the further development of the ZOLLER »venturion«. The new, variable »cockpit« control unit allows the user to work comfortably, and with 180 degrees of accessibility it is much easier to change tools. With the »eQ« Plus single-hand operating device, you can position the optic carrier in no time at all. The membrane keypad ensures user comfort, as does the intuitive user dialog of the »pilot 3.0« software. Unrivalled process safety is also ensured due to the perfect interplay of mechanical and electronic components. With »venturion«, your work has never been so pleasant, or so efficient.



venturion
450

The **Tension** Is Mounting — and the Excitement Grows

Insert a tool, push a button, finished. That's how simple it is to clamp tools using the universal »ace« high-precision spindle from ZOLLER — always with the same precision, accurate and reliable to the last μm . Steep or hollow shank tapers, Capto, VDI or KM, and with shank diameters from 3 to 32 mm — all attachment holders can be replaced in less than 10 seconds with μm precision. No wonder these power-activated spindles have been impressing users throughout the world for decades. And with the new, ergonomically optimized design, enthusiasm will no doubt continue to grow.

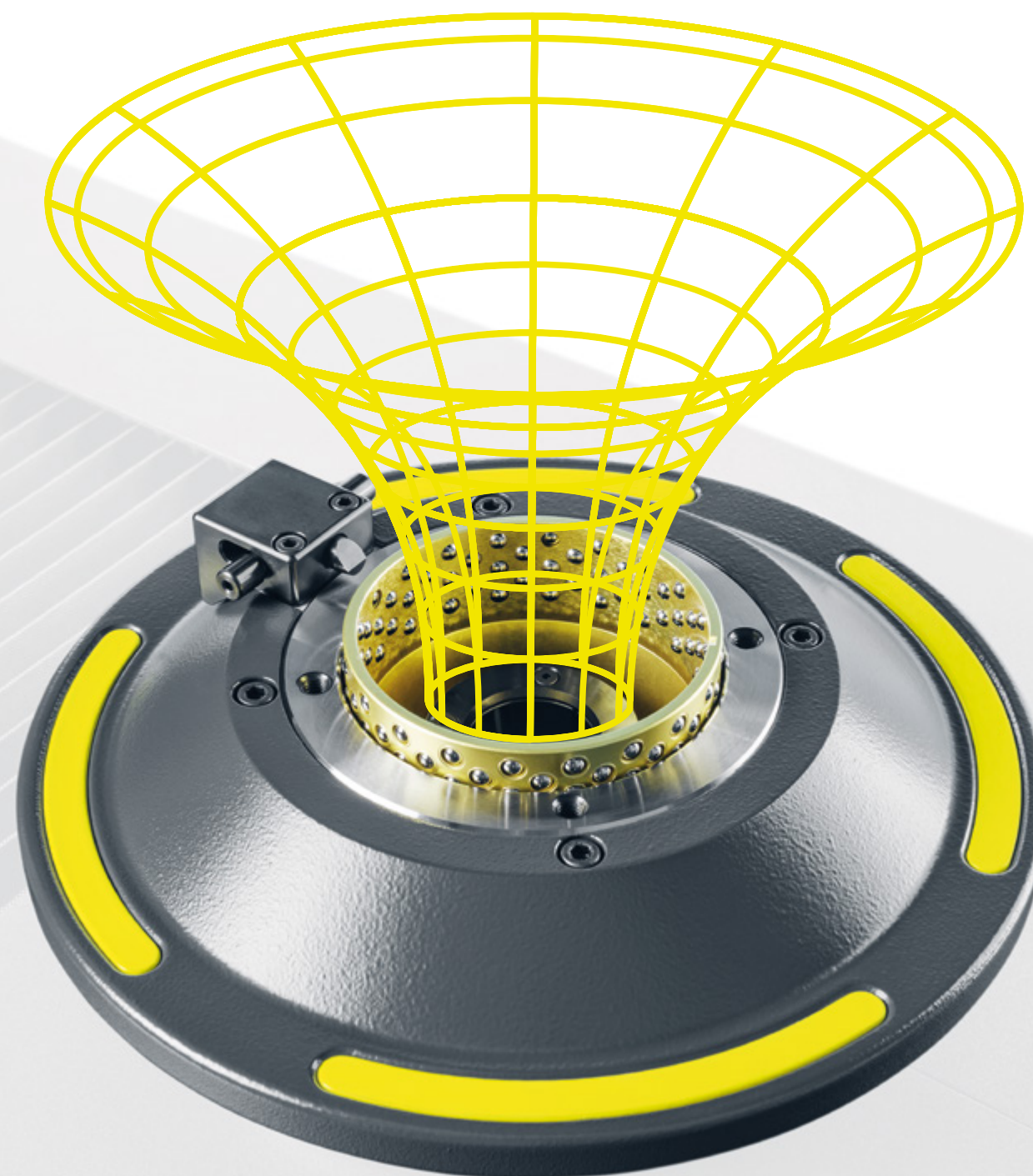
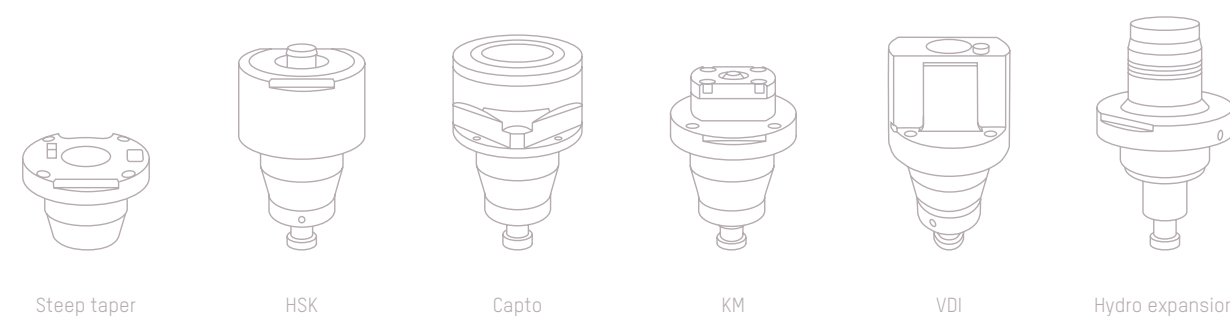

venturion
450

Welcome to the Future

Always guaranteed with ZOLLER: a secure connection to the future. Not only can you integrate our solutions easily into your existing systems, you can also adapt them quickly and flexibly to new challenges. You will always be a step ahead of the competition.

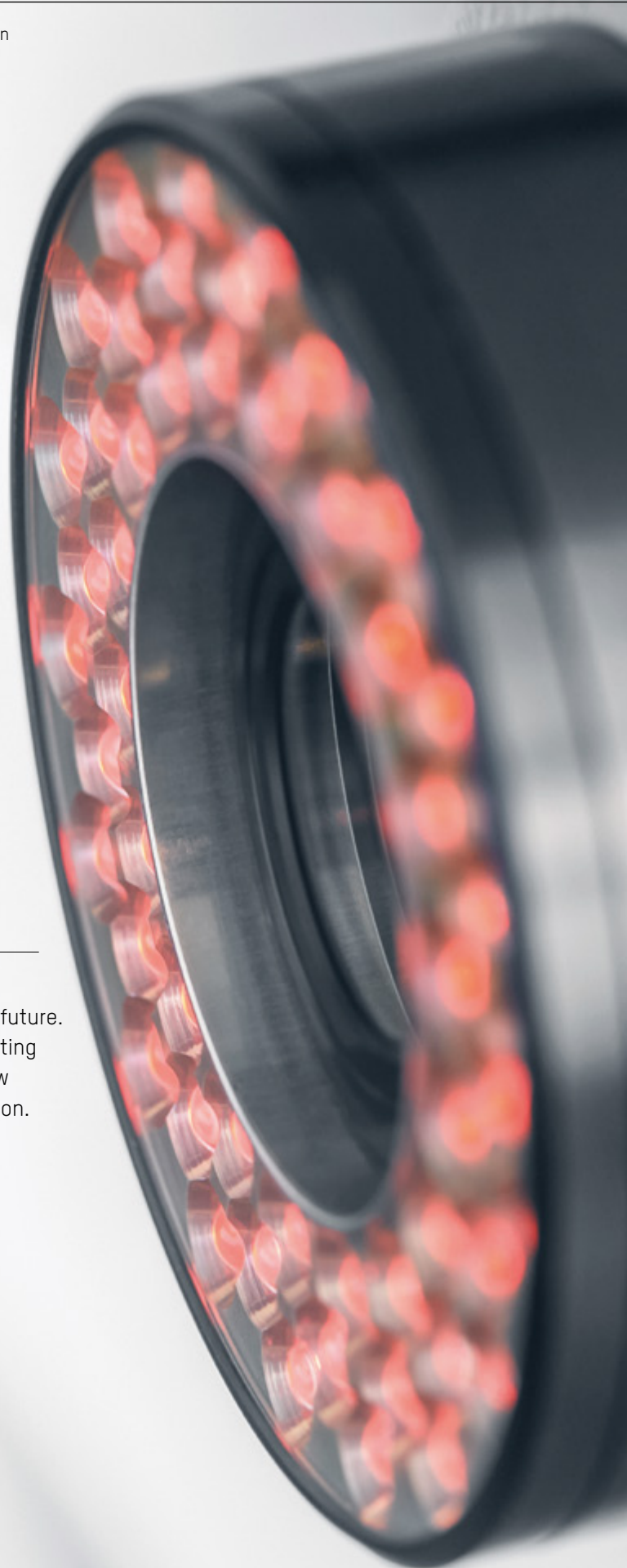

»venturion 450« Technical Data

Measuring Range, Z Axis	450 / 620 / 820 mm (17.72 / 24.41 / 32.28 in)	
Tool Diameter	420 / 620 mm (16.54 / 24.41 in)	
Snap Gauge	100 mm (3.94 in)	
Drive Options	Manual	⊙
	Micro Adjustment Hand Wheel	⊙
	CNC Drives	⊙
	Separate Clamping Z/X	●
Measuring Machine Control	24" »pilot 3.0«	●
ZOLLER »cockpit«	Height Adjustable	●
180° Tool Spindle Accessibility		●
Transmitted Light Camera System	Standard	⊙
Tool Holder Spindle	»ace« Size 1	●
	»ace« Hand Wheel With Underhand Grip	●
Spindle Options	Manual	⊙
	Autofocus	⊙
Length Adjustment – Tools	R0D Rotary Encoder	⊙
	»asza« lin	⊙
	»asza« rot	⊙
Tool Identification	Man./»mslz«	⊙
	Height Adjustment / CNC (Automatic)	⊙
	Head Bolts (Automatic)	⊙
Center Height Measuring Camera	External Manual Read/Write Station	⊙
	DME	⊙
Cutting Edge Inspection LED Light Ring		●
Tool Inspection		⊙
Machine Table		●
Shelves	For Printer	●
	For Tool Posts	●
Membrane Keypad		●
»eQ« Plus Single-hand Operating Device	With Programmable Button	●

● standard ⊙ option

Measurably More Profit

With ZOLLER »venturion« and TMS Tool Management Solutions, you reduce tool costs and make full use of your machines because you measure tools especially quickly, easily, and operator-independent. Moreover, you network your presetting and measuring machine with all the stations in the manufacturing process using the z.One central tool database. That means the right tool is at the right place at the right time. And your profits will increase markedly!



ZOLLER Solutions

The Solution for Your Success

More speed, greater flexibility, safer processes — with ZOLLER system solutions you'll get more out of all aspects of your production. To assure this, we combine hardware, software, and services with our unique manufacturing expertise for you. Everything from a single supplier. Everything for your success. Everything with ZOLLER solutions.

venturion | 450

Subject to technical modifications. The depicted machines may include options, accessories, and control variants. Delivered products have product safety labels in accordance with ISO 3864-2 or ANSI/NEMA Z535.4. BRVEN450.00-US 04/2018.

www.zoller-usa.com

ZOLLER Inc. | Tool Presetting and Measuring Machines
3900 Research Park Drive | Ann Arbor, MI, 48108 USA
Tel: (734) 332-4851 | Fax: (734) 332-4852
sales@zoller-usa.com

ZOLLER
expect great measures®