



NC ROTARY TABLE

Tilting NC Rotary Table TT150

**High stiffness and clamp torque of main spindle!
Compact designed body with minimized total height keeps less high-column of machine.**

- Suitable for No.30 machining centers (*High-column specification may be required to suit a variety of machine models.)
- High clamp torque
- Built-in Rotary Joint as option*



TT150

*CE correspondence

※In specification with the foreign trade control ordinance, permission of the ministry of economy, trade and industry is required when exporting twin axis products overseas.

Complete built-in rotary joint (option)

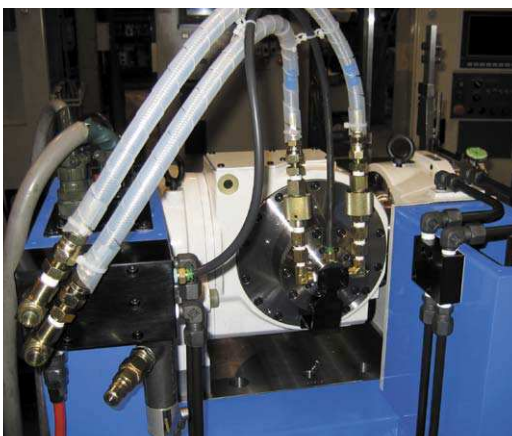

Simplified Pipework

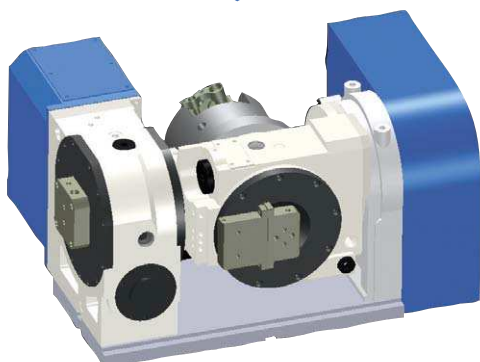

Sample Application



▲Only Kitagawa can offer this combination of NC Rotary Table and chuck

- Installation of optional rotary joint

4th axis specifications

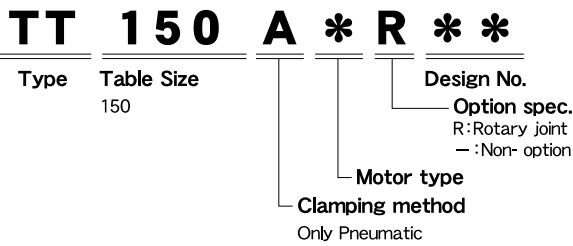

M signal specification

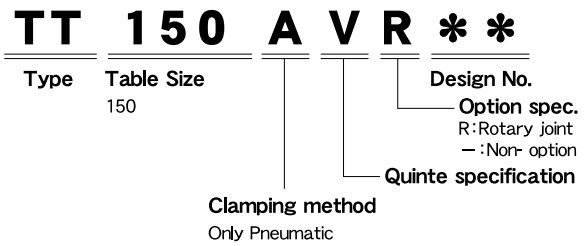

Specifications

Model		TT150	
Tilting angle		-20° ~ +110°	
Table dia (mm)		φ 150	
Register diameter on Face Plate (mm)		φ 60H7	
Spindle through hole diameter (mm)		φ 40	
Centre Height (mm)		150	
Clamping method		Pneumatic	
Clamping torque (N·m) (In pneumatic 0.5MPa)	Rotating axis	350	
	Tilting axis	550	
Motor axis reduced inertia (kg·m ²)	Rotating axis	0.000242	
	Tilting axis	0.000132	
Servomotor (for FANUC specification)		α iF 2/5000	
Gear ratio	Rotating axis	1/72	
	Tilting axis	1/180	
Max. spindle speed	for FANUC specification	Rotating axis (for min ¹ /Motor3000min ¹)	41.6
		Tilting axis (for min ¹ /Motor3000min ¹)	16.6
	M signal specification	Rotating axis (for min ¹ /Motor3000min ¹)	41.6
		Tilting axis (for min ¹ /Motor3000min ¹)	16.6
Allowable work inertia (kg·m ²)		0.14	
Indexing accuracy (sec)	Rotating axis	30	
	Tilting axis	60	
Repeatability (sec)		4	
Mass of product (kg)		141	
Built-in rotary joint (as an option · P97reference)		RJ40FTT150 Hyd./pneumatic 4-port + Exclusive pneumatic 1 port of air	
Allowable Load	at horizontal (kg)	50	
	at tilted (kg)	30	
Allowable load (When clamped to table)	F (kN)	4	
	F×L (N·m)	550	
	F×L (N·m)	350	
Allowable cutting torque	T (N·m)	190	
Moment of tilting weight capacity	W×L (kgf·m)	11	

Note) 1. The switch for pressure checking is incorporated to all series except TC/DM of NC tables. 2. The solenoid valve for the table clamp is incorporated. 3. Neither cable nor hose is fitted between NC rotary table and machine tool... 4. Each product mass is determined by a Kitagawa M signal spec.

■Dimensions [4th axis specifications]

TT150

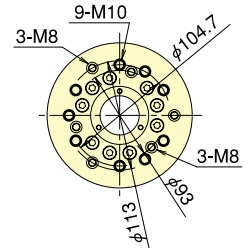
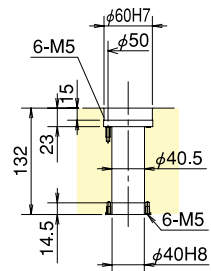
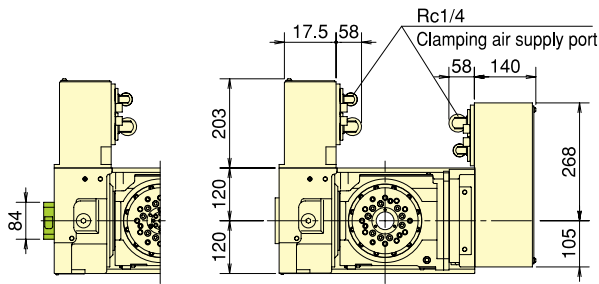

Thru-Hole Diameter

Detailed table hole

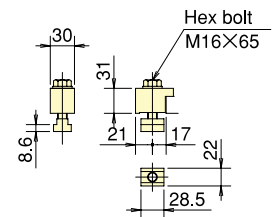
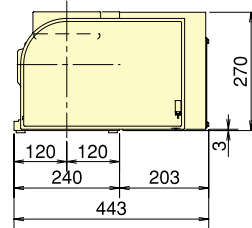
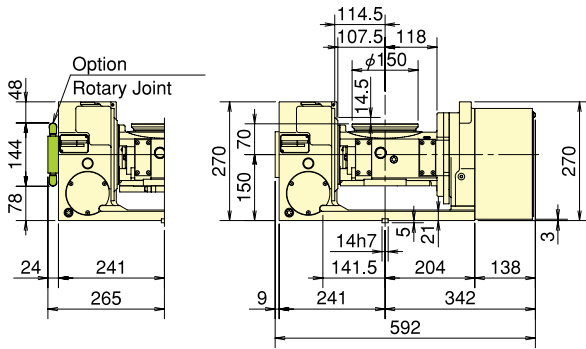

Clamping Device

※The above dimensions are the same as FANUC spec.
Those dimensions may vary from motor to motor that is mounted.

■Dimensions [Kitagawa own controller]

*The dimensions may vary from motor to motor that is mounted.

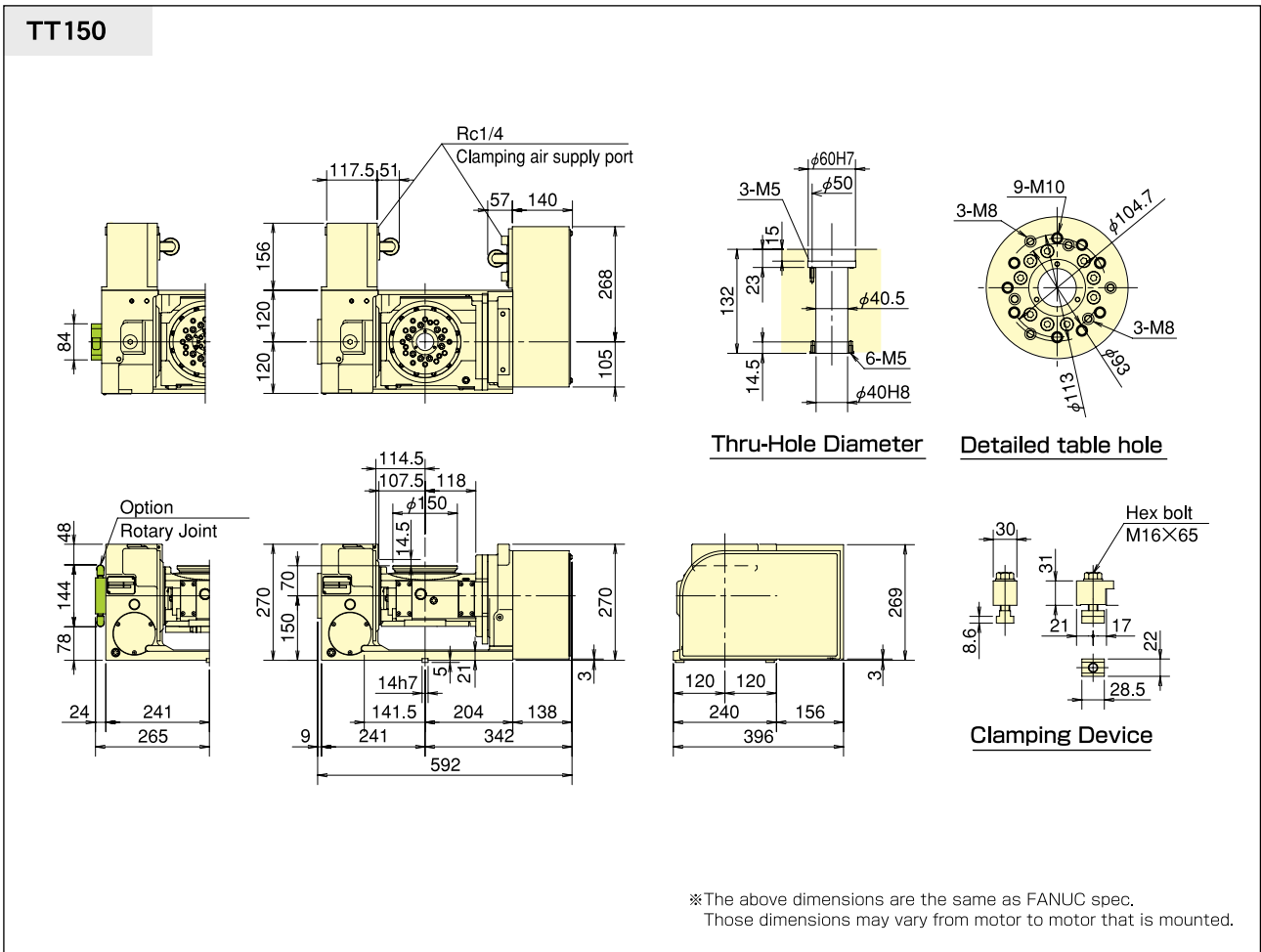

DATA Tilting NC table • Work loadable area

TT150

