

仕様 SPECIFICATIONS	
割出精度 INDEXING ACCURACY	20 sec以内
再現精度 REPEATABILITY	4 sec以内
テーブル最高回転速度 MAXIMUM ROTATION SPEED	16.6 min ⁻¹ [E-9 MOTOR 2000 min ⁻¹]
クランプトルク CLAMPING TORQUE	1200N·m [E-9 PNEUMATIC PRESS 0.5MPa]
許容最大空圧力 MAXIMUM PNEUMATIC PRESS	0.7 MPa
許容積載質量 ALLOWABLE MASS OF WORK	横HORZ 350 kg 立VERT 180 kg
許容積載ワーク径 ALLOWABLE WORK DIA.	φ320 mm
総減速比 TOTAL REDUCTION RATIO	1/120
製品質量 MASS OF ROTARY TABLE	130 kg
駆動系一方向機軸インertia MACHINE INERTIA (REDUCED TO MOTOR SHAFT)	0.00024kg·m ²

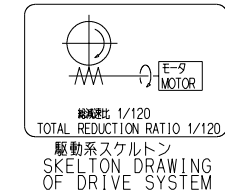
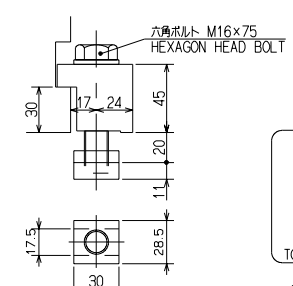
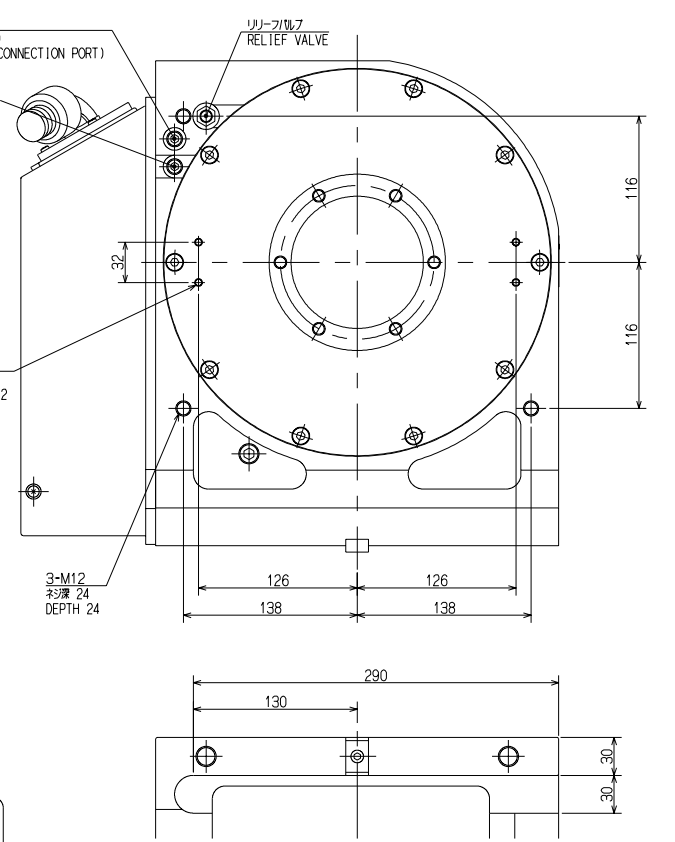
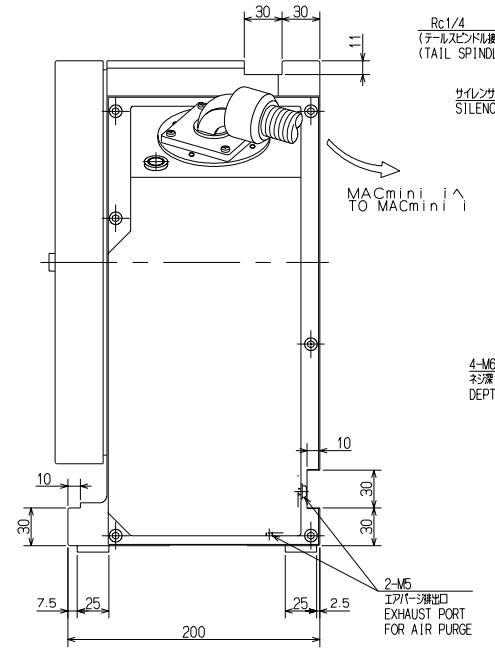
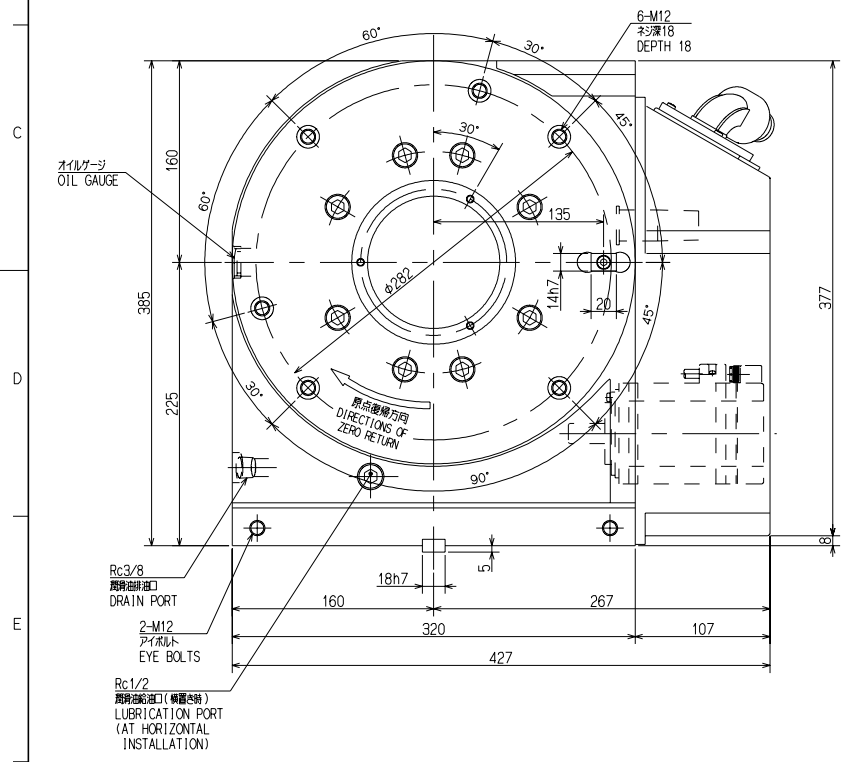

クランプ器具 付属品 4組
CLAMPING PARTS ACCESSORY 4 PAIR

CAREER	SCALE	TYPE	MRM320R20	WEIGHT	kg
MANAGER	1:3	NAME	NCテーブル NC ROTARY TABLE		
CHIEF	3RD ANGLE	NAME	MRM320R20 ガイワイ		
DRAWN BY		DRW NO.	61E 24 4583		2
KITAGAWA IRON WORKS CO., LTD.	DATE				