

**SPANNBEREICHE
CLAMPING RANGES**

- Beachten Sie die maximal zulässigen Spannbereiche!
- Do not exceed maximum Clamping ranges!

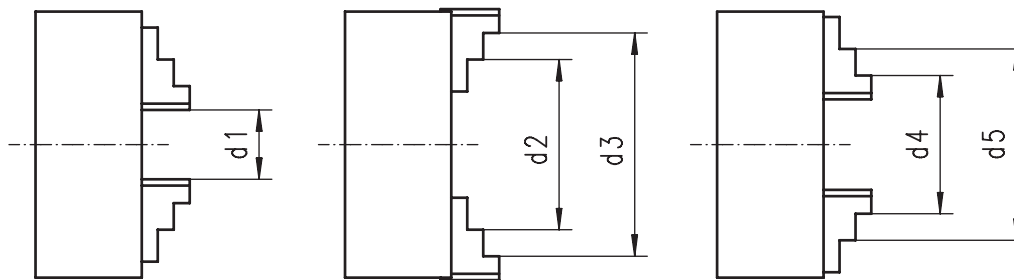

32, 35**, 36**, 37****

| Futtergröße [mm] Chuck size [mm] | Harte, einteilige Backen Hard solid jaws | | | | | Harte, geteilte Backen Hard 2-piece jaws | | | | | Max. Umlaufdurchmesser Max. swing diameter |
|-------------------------------------|---|---------|---------|---------|---------|---|----------|----------|----------|----------|---|
| | d1 | d2 | d3 | d4 | d5 | d1 | d2 | d3 | d4 | d5 | |
| 80 | 2-27 | 25-50 | 48-71 | 22-46 | 45-69 | - | - | - | - | - | 90 |
| 100 | 3-33 | 32-62 | 62-93 | 25-56 | 56-87 | - | - | - | - | - | 117 |
| 125 | 3-50 | 39-83 | 80-125 | 34-74 | 72-115 | 3-50 | 52-96 | 95-125 | 34-76 | 75-118 | 151 |
| 160 | 3-64 | 50-107 | 98-160 | 42-100 | 94-154 | 3-64 | 62-121 | 115-160 | 42-97 | 88-146 | 204 |
| 200 | 4-90 | 60-145 | 130-200 | 52-135 | 120-202 | 4-90 | 72-156 | 133-200 | 50-130 | 105-190 | 246 |
| 250 | 5-118 | 77-188 | 160-250 | 62-174 | 145-256 | 5-118 | 86-197 | 160-250 | 58-165 | 125-235 | 306 |
| 315 | 10-131 | 90-215 | 190-315 | 78-200 | 172-299 | 10-131 | 103-226 | 190-315 | 65-182 | 145-265 | 384 |
| 400 | 10-180 | 103-272 | 230-400 | 85-252 | 210-380 | 10-180 | 127-294 | 230-400 | 72-228 | 165-329 | 472 |
| 500 | 20-235 | 140-357 | 276-500 | 120-335 | 245-476 | 20-235 | 110-400 | 190-500 | 120-410 | 200-485 | 600 |
| 630 | 30-335 | 180-487 | 345-630 | 160-465 | 325-630 | 30-335 | 120-570 | 200-630 | 140-590 | 210-630 | 770 |
| 800 | 150-482 | 302-634 | 468-800 | 282-614 | 448-780 | 150-482 | 240-724 | 316-800 | 252-736 | 328-800 | 940 |
| 1000 | - | - | - | - | - | 100-600 | 350-880 | 430-1000 | 425-900 | 500-1000 | 1140 |
| 1250 | - | - | - | - | - | 480-1000 | 585-1090 | 740-1250 | 580-1070 | 750-1250 | 1390 |
| 1400 | - | - | - | - | - | 480-1150 | 585-1240 | 750-1400 | 580-1220 | 750-1400 | 1540 |
| 1600 | - | - | - | - | - | 480-1330 | 585-1420 | 750-1600 | 580-1400 | 750-1600 | 1740 |
| 1800 | - | - | - | - | - | 480-1530 | 585-1620 | 750-1800 | 580-1600 | 750-1800 | 1950 |
| 2000 | - | - | - | - | - | 480-1725 | 585-1815 | 750-2000 | 580-1800 | 750-2000 | 2150 |

43**

| Futtergröße [mm] Chuck size [mm] | d1 min. | d2 max. | Max. Umlaufdurchmesser Max. swing diameter |
|-------------------------------------|---------|---------|---|
| 85 | 3 | 85 | 101 |
| 100 | 3 | 10 | 116 |
| 125 | 8 | 125 | 150 |
| 160 | 8 | 160 | 185 |
| 200 | 10 | 200 | 235 |
| 250 | 10 | 250 | 296 |
| 315 | 15 | 315 | 369 |
| 350 | 15 | 350 | 404 |
| 400 | 20 | 400 | 465 |
| 500 | 45 | 500 | 570 |
| 630 | 50 | 630 | 720 |
| 800 | 50 | 800 | 900 |
| 1000 | 170 | 1000 | 1090 |
| 1250 | 170 | 1250 | 1340 |
| 1400 | 470 | 1400 | 1515 |
| 1600 | 470 | 1600 | 1715 |
| 1800 | 470 | 1800 | 1920 |
| 2000 | 470 | 2000 | 2120 |

3864, 3865

| Futtergröße [mm] Chuck size [mm] | Harte, einteilige Backen Hard solid jaws | | | | | Harte, geteilte Backen Hard 2-piece jaws | | | | | Max. Umlaufdurchmesser Max. swing diameter |
|-------------------------------------|---|---------|---------|---------|---------|---|----------|----------|----------|----------|---|
| | d1 | d2 | d3 | d4 | d5 | d1 | d2 | d3 | d4 | d5 | |
| 125 | 6-43 | 42-78 | 83-120 | 34-68 | 74-110 | 6-43 | 50-87 | 94-125 | 33-70 | 76-119 | 151 |
| 160 | 8-64 | 52-107 | 102-160 | 47-100 | 98-154 | 8-64 | 67-121 | 118-160 | 45-97 | 92-146 | 204 |
| 200 | 8-90 | 64-145 | 132-200 | 55-135 | 121-202 | 8-90 | 74-156 | 134-200 | 52-130 | 109-190 | 246 |
| 250 | 12-118 | 82-188 | 165-250 | 68-174 | 150-256 | 12-118 | 82-188 | 164-250 | 68-174 | 150-256 | 306 |
| 315 | 12-131 | 95-215 | 192-315 | 82-200 | 178-299 | 12-131 | 108-226 | 153-315 | 68-182 | 150-265 | 384 |
| 400 | 15-202 | 140-308 | 232-400 | 95-280 | 213-400 | 15-202 | 132-296 | 236-400 | 73-252 | 169-352 | 472 |
| 500 | 30-235 | 152-361 | 291-500 | 132-335 | 270-474 | 30-235 | 121-402 | 197-478 | 135-413 | 210-489 | 600 |
| 630 | 40-335 | 192-487 | 358-630 | 175-467 | 340-630 | 40-335 | 132-555 | 210-630 | 150-585 | 220-630 | 770 |
| 800 | - | - | - | - | - | 180-482 | 290-644 | 420-800 | 285-635 | 440-800 | 940 |
| 1000 | - | - | - | - | - | 310-600 | 410-950 | 580-1000 | 415-840 | 530-1000 | 1140 |
| 1250 | - | - | - | - | - | 480-1000 | 585-1090 | 740-1250 | 580-1070 | 770-1250 | 1390 |
| 1400 | - | - | - | - | - | 480-1150 | 585-1240 | 750-1400 | 580-1220 | 770-1400 | 1540 |
| 1600 | - | - | - | - | - | 480-1330 | 585-1420 | 750-1600 | 580-1400 | 770-1600 | 1740 |
| 1800 | - | - | - | - | - | 480-1530 | 585-1620 | 750-1800 | 580-1600 | 770-1800 | 1950 |
| 2000 | - | - | - | - | - | 480-1725 | 585-1815 | 750-2000 | 580-1800 | 770-2000 | 2150 |

4505, 4605, 4705 4805

| Futtergröße [mm] Chuck size [mm] | d1 min. | d2 max. | Max. Umlaufdurchmesser Max. swing diameter [mm] |
|-------------------------------------|---------|---------|--|
| 200 | 4 | 200 | 240 |
| 250 | 5 | 250 | 300 |
| 315 | 10 | 315 | 370 |
| 400 | 15 | 400 | 470 |
| 500 | 20 | 500 | 575 |
| 630 | 30 | 630 | 725 |
| 800 | 50 | 800 | 900 |
| 1000 | 175 | 1000 | 1100 |
| 1250 | 350 | 1250 | 1345 |
| 1400 | 350 | 1400 | 1520 |
| 1600 | 350 | 1600 | 1725 |
| 1800 | 350 | 1800 | 1925 |
| 2000 | 350 | 2000 | 2130 |

- 1
- 2
- 3
- 4
- 5
- 6
- 7

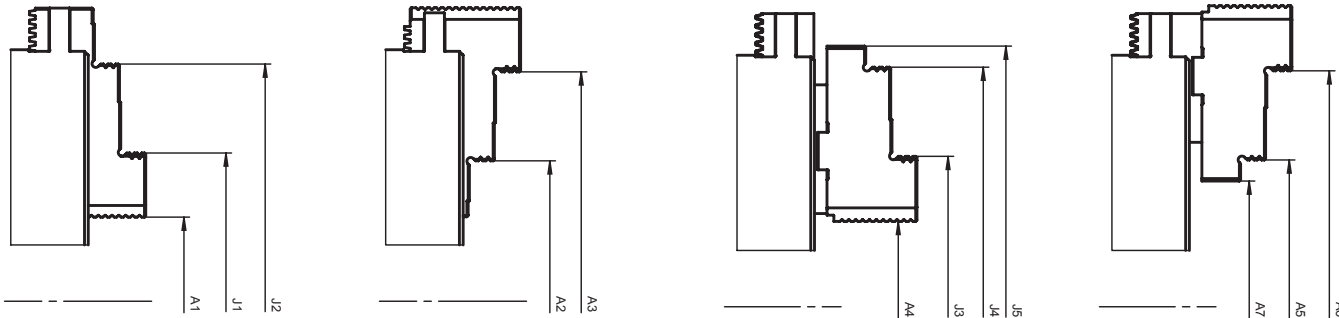

SPANNBEREICHE
CLAMPING RANGES

34**

| Futtergröße [mm] | Harte, einteilige Backen Hard solid jaws | | | | | Harte, geteilte Backen Hard 2-piece jaws | | | | | | |
|------------------|---|---------|---------|---------|---------|---|----------|----------|----------|----------|---------|--------|
| | A1 | J1 | J2 | A2 | A3 | A4 | J3 | J4 | A5 | A6 | J5 | A7 |
| 125 | 4-29 | 28-53 | 100-125 | 38-63 | 100-125 | 10-25 | 38-80 | 107-125 | 27-62 | 90-125 | 72-110 | 60-95 |
| 160 | 4-90 | 34-120 | 90-160 | 61-150 | 90-160 | 10-39 | 60-134 | 86-160 | 100-147 | 120-160 | 132-160 | 35-88 |
| 200 | 5-105 | 49-149 | 100-200 | 70-170 | 100-200 | 10-50 | 70-184 | 103-200 | 100-174 | 120-200 | 152-200 | 45-124 |
| 250 | 8-130 | 66-188 | 128-250 | 81-170 | 120-250 | 10-64 | 94-170 | 174-250 | 80-154 | 160-235 | 195-250 | 60-185 |
| 315 | 10-155 | 74-200 | 142-315 | 95-189 | 152-315 | 24-88 | 108-210 | 214-315 | 100-215 | 145-315 | 236-315 | 80-195 |
| 400 | 10-174 | 120-276 | 258-400 | 118-278 | 260-413 | 15-168 | 124-272 | 263-412 | 115-268 | 260-410 | - | - |
| 500 | 52-254 | 158-358 | 290-500 | 165-360 | 306-500 | 64-256 | 166-360 | 306-502 | 165-360 | 305-500 | - | - |
| 630 | - | - | - | - | - | 25-326 | 165-490 | 335-630 | 210-512 | 352-654 | - | - |
| 800 | - | - | - | - | - | 170-410 | 335-573 | 475-715 | 368-660 | 510-800 | - | - |
| 1000 | - | - | - | - | - | 300-630 | 480-860 | 620-1000 | 570-860 | 715-1000 | - | - |
| 1200 | - | - | - | - | - | 480-895 | 645-1060 | 785-1200 | 770-1060 | 910-1200 | - | - |

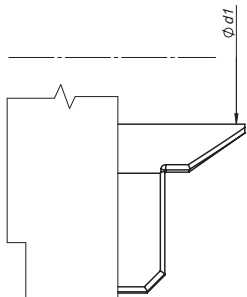

3868

| Futtergröße [mm] | Ø d1 |
|------------------|--------|
| 3868-85 | 1,5-25 |

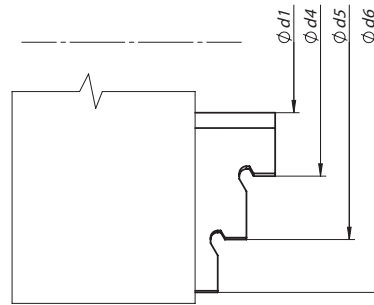

3286

| Futtergröße [mm] | Ø d1 | Ø d2 | Ø d3 | Ø d4 | Ø d5 | Ø d6 | Ø d7 |
|------------------|--------|-------|-------|-------|-------|-------|------|
| 3286-49-M12x1 | 0,5-32 | 17-39 | 35-57 | 20-27 | 37-63 | 50-75 | 5-14 |
| 3286-60-M16x1 | 0,5-35 | 20-42 | 38-60 | 20-52 | 37-70 | 61-85 | 5-20 |

- 1
- 2
- 3
- 4
- 5
- 6
- 7

MAXIMAL ZULÄSSIGE DREHZAHLEN (MAX. U/MIN)
MAXIMUM PERMISSIBLE ROTATION SPEEDS (RPM)

Die zulässige Drehzahl des Futter ist von vielen Faktoren abhängig, wie z.B. Drehparameter, Werkstückgewicht und dessen Unwucht, Typ der Bearbeitung (Dauer- oder Aussetzbetrieb) usw.

Die maximalen zulässigen Drehzahlen, die in den nachfolgenden Tabellen angegeben sind, dürfen keine Spannkraftminderung auf die Hälfte des Anfangswertes verursachen. Bei Arbeiten unter normalen/stabilen Bedingungen (Werkstück, Werkzeuge, Arbeitsbedingungen) ist eine Spannkraftminderung auf bis zu 67% des Anfangswertes zulässig.

Dies bezieht sich auf Futter mit Standardbacken, die nicht über den äußeren Durchmesser des Futter hinausgehen und gleichzeitiger Beibehaltung der Wuchtgüte des „bearbeiteten Werkstück“ (nicht mehr als 20gmm/kg). Futter und Backen müssen einen guten technischen Zustand aufweisen. In anderen Fällen siehe den in der PN-M-60650 angegebenen Berechnungen.

Admissible revolutions of the chuck depend on many factors, such as cutting parameters, weight of the workpiece and its balance or type of machining (interrupted or continuous turning) etc.

The max. speeds as indicated in the table below should not cause a decrease of the clamping force to the half of its initial value. When machining in the stable conditions (machining material, tools, working conditions), the clamping force may be reduced by up to 67% of its initial value.

This relates to the chuck equipped with standard jaws, that do not protrude beyond the outer diameter of the chuck and the unbalance condition of the 'chuck-machining workpiece' is maintained (not exceeding 20gmm/kg). The chuck and jaws must be in good condition. Otherwise, refer to the calculations as indicated in the PN-M-60650.

3105, 32**, 35**, 36**, 37**, 38**

| Futtergröße [mm] Chuck size [mm] | Max. U/min Max. rpm | | | |
|-------------------------------------|---------------------------|------------|------------------------------|-------|
| | Stahlkörper Steel body | | Gusskörper Cast iron body | |
| | 35**, 356*, 37** | 38**, 386* | 3105, 32**, 36** | 38** |
| 80 | 7.000 | - | 5.000 | - |
| 100 | 6.300 | - | 4.500 | - |
| 125 | 5.500 | 3.800 | 4.000 | - |
| 160 | 4.600 | 3.200 | 3.600 | - |
| 200 | 4.000 | 2.800 | 3.000 | 2.000 |
| 250 | 3.500 | 2.400 | 2.500 | 1.500 |
| 315 | 2.800 | 1.900 | 2.000 | 1.200 |
| 400 | 2.000 | 1.400 | 1.600 | 800 |
| 500 | 1.300 | 900 | 1.000 | 600 |
| 630 | 1.000 | 700 | 800 | 500 |
| 800 | 800 | 560 | 600 | 400 |
| 1000 | 600 | 400 | 400 | - |
| 1250 | 500 | 350 | 300 | - |
| 1400 | 440 | - | 250 | - |
| 1600 | 380 | - | 220 | - |
| 1800 | 340 | - | 190 | - |
| 2000 | 300 | - | 170 | - |

43**

| Futtergröße [mm] Chuck size [mm] | Max. U/min Max. rpm | |
|-------------------------------------|---------------------------|------------------------------|
| | Stahlkörper Steel body | Gusskörper Cast iron body |
| | 80 | 7.640 |
| 85 | 7.190 | - |
| 100 | 6.120 | - |
| 125 | 4.890 | - |
| 140 | 4.370 | - |
| 160 | 3.820 | - |
| 200 | 3.060 | 1.800 |
| 250 | 2.450 | 1.500 |
| 315 | 1.940 | 1.200 |
| 400 | 1.530 | 860 |
| 500 | 1.220 | 690 |
| 630 | 970 | 550 |
| 800 | 760 | 430 |
| 1000 | 610 | 340 |
| 1250 | 490 | 280 |
| 1400 | 440 | 250 |
| 1600 | 380 | 220 |
| 1800 | 340 | 190 |
| 2000 | 300 | 170 |

4505, 4605, 4705, 4805

| Futtergröße [mm] Chuck size [mm] | Max. U/min Max. rpm | | | |
|-------------------------------------|------------------------|-------|-------|-------|
| | 4505 | 4605 | 4705 | 4805 |
| | 200 | 2.500 | 2.000 | 3.000 |
| 250 | 2.000 | 1.800 | 2.500 | 2.000 |
| 315 | 1.500 | 1.200 | 2.000 | 1.700 |
| 400 | 1.000 | 800 | 1.500 | 1.300 |
| 500 | 700 | 600 | 1.000 | 800 |
| 630 | 540 | 480 | 750 | 660 |
| 800 | 420 | 360 | 600 | 520 |
| 1000 | 280 | 240 | 380 | 330 |
| 1250 | 210 | 170 | - | - |

34*4, 34*5

| Futtergröße [mm] Chuck size [mm] | Max. U/min Max. rpm |
|-------------------------------------|------------------------|
| 125 | 6.000 |
| 160 | 5.400 |
| 200 | 4.600 |
| 250 | 4.200 |
| 315 | 3.300 |

1

2

3

4

5

6

7

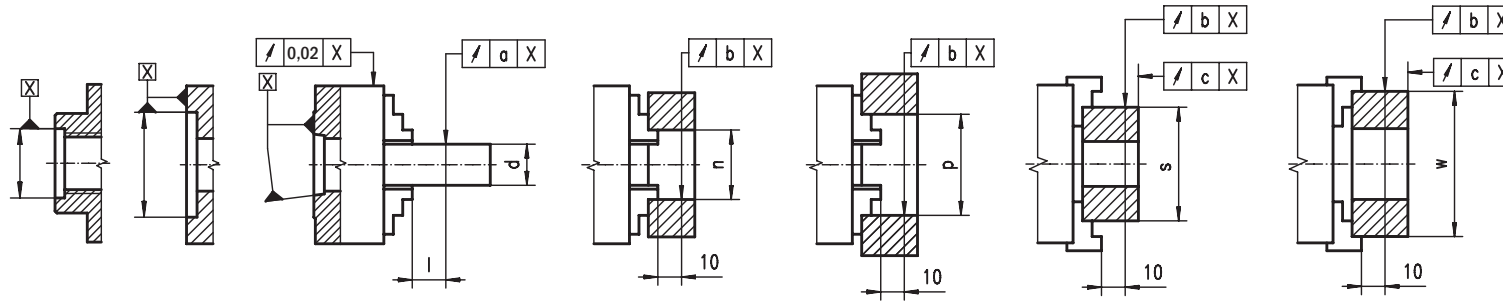

RUNDLAUFGENAUIGKEIT
CENTERING ACCURACY

32**, 35**, 36**, 37**, 38**

| Futtergröße [mm] Chuck size [mm] | l | d | | n | p | s | w | | Rundlaufgenauigkeit [mm] | | | | | | | | | | | | |
|-------------------------------------|-----|-----|-----|-----|-----|-----|--------------------------|------------------------|--------------------------|-------|-------|------------------|-------|-------|------------|-------|-------|------------|-------|-------|-------|
| | | | | | | | Harte, einteilige Backen | Harte, geteilte Backen | Centering accuracy [mm] | | | | | | | | | | | | |
| | | | | | | | Hard solid jaws | Hard 2-piece jaws | 35** PREMIUM | | | 35**, 37**, 38** | | | 32**, 36** | | | 3284, 3285 | | | |
| | | | | | | | | a | b | c | a | b | c | a | b | c | a | b | c | | |
| 80 | 40 | 10 | - | 14 | 40 | 60 | 35 | 63 | - | 0,010 | 0,013 | 0,008 | 0,020 | 0,025 | 0,015 | 0,020 | 0,025 | 0,015 | 0,050 | 0,075 | 0,040 |
| 100 | 40 | 10 | 14 | 18 | 40 | 75 | 50 | 80 | - | 0,010 | 0,013 | 0,008 | 0,020 | 0,025 | 0,015 | 0,020 | 0,025 | 0,015 | 0,050 | 0,075 | 0,040 |
| 125 | 60 | 18 | 25 | 30 | 50 | 100 | 62 | 100 | 120 | 0,015 | 0,018 | 0,010 | 0,030 | 0,035 | 0,020 | 0,030 | 0,035 | 0,020 | 0,050 | 0,075 | 0,040 |
| 160 | 60 | 18 | 30 | 40 | 50 | 135 | 88 | 100 | 150 | 0,015 | 0,018 | 0,010 | 0,030 | 0,035 | 0,020 | 0,030 | 0,035 | 0,020 | 0,050 | 0,075 | 0,040 |
| 200 | 80 | 30 | 40 | 53 | 80 | 162 | 96 | 160 | 185 | 0,020 | 0,023 | 0,013 | 0,040 | 0,045 | 0,025 | 0,040 | 0,045 | 0,025 | 0,050 | 0,075 | 0,040 |
| 250 | 80 | 30 | 53 | 75 | 80 | 200 | 150 | 160 | 225 | 0,020 | 0,023 | 0,013 | 0,040 | 0,045 | 0,025 | 0,040 | 0,045 | 0,025 | 0,080 | 0,075 | 0,070 |
| 315 | 120 | 53 | 75 | 100 | 125 | 252 | 210 | 250 | 300 | 0,025 | 0,028 | 0,015 | 0,050 | 0,055 | 0,030 | 0,050 | 0,055 | 0,030 | 0,080 | 0,075 | 0,070 |
| 400 | 120 | 53 | 100 | 125 | 125 | 282 | 250 | 250 | 350 | 0,030 | 0,033 | 0,015 | 0,060 | 0,065 | 0,030 | 0,060 | 0,065 | 0,030 | - | - | - |
| 500 | 160 | 75 | 100 | 125 | 200 | 282 | 300 | 400 | 400 | 0,050 | 0,055 | 0,030 | 0,100 | 0,075 | 0,050 | 0,100 | 0,100 | 0,050 | - | - | - |
| 630 | 160 | 75 | 125 | 160 | 200 | 325 | 400 | 400 | 400 | 0,070 | 0,075 | 0,050 | 0,100 | 0,100 | 0,050 | 0,100 | 0,100 | 0,050 | - | - | - |
| 800 | 160 | 160 | 200 | 250 | 325 | 500 | 400 | 500 | 500 | 0,100 | 0,100 | 0,050 | 0,150 | 0,150 | 0,060 | 0,150 | 0,150 | 0,060 | - | - | - |
| 1000 | 160 | 250 | 315 | 400 | 500 | 630 | 500 | - | 630 | 0,120 | 0,120 | 0,060 | 0,150 | 0,150 | 0,080 | 0,150 | 0,150 | 0,080 | - | - | - |
| 1250 | 200 | - | - | 500 | 800 | 800 | 1000 | - | 1000 | 0,120 | 0,120 | 0,060 | 0,150 | 0,150 | 0,080 | 0,150 | 0,150 | 0,080 | - | - | - |
| 1400 | 200 | - | - | 500 | 800 | 800 | 1000 | - | 1000 | 0,120 | 0,120 | 0,060 | 0,150 | 0,150 | 0,100 | 0,180 | 0,180 | 0,120 | - | - | - |
| 1600 | 200 | - | - | 500 | 800 | 800 | 1000 | - | 1000 | 0,150 | 0,150 | 0,080 | 0,180 | 0,180 | 0,120 | 0,200 | 0,200 | 0,160 | - | - | - |
| 1800 | 200 | - | - | 500 | 800 | 800 | 1000 | - | 1000 | 0,200 | 0,200 | 0,120 | 0,220 | 0,220 | 0,160 | 0,250 | 0,250 | 0,200 | - | - | - |
| 2000 | 200 | - | - | 500 | 800 | 800 | 1000 | - | 1000 | 0,200 | 0,200 | 0,120 | 0,220 | 0,220 | 0,160 | 0,250 | 0,250 | 0,200 | - | - | - |

34**

| Futtergröße [mm] Chuck size [mm] | l | d | | n | p | s | w | Rundlaufgenauigkeit [mm] | | | |
|-------------------------------------|-----|-----|-----|-----|-----|-----|-----|--------------------------|-------|-------|-------|
| | | | | | | | | Centering accuracy [mm] | | | |
| | | | | | | | | a | b | c | |
| 125 | 60 | 14 | 20 | 29 | 50 | 100 | 95 | 125 | 0,015 | 0,015 | 0,01 |
| 160 | 60 | 14 | 20 | 38 | 50 | 135 | 100 | 160 | 0,02 | 0,015 | 0,01 |
| 200 | 80 | 14 | 22 | 50 | 80 | 162 | 150 | 200 | 0,02 | 0,02 | 0,01 |
| 250 | 80 | 15 | 32 | 64 | 80 | 200 | 180 | 250 | 0,02 | 0,02 | 0,01 |
| 315 | 120 | 20 | 64 | 89 | 125 | 252 | 225 | 290 | 0,025 | 0,025 | 0,01 |
| 400 | 120 | 53 | 100 | 125 | 125 | 282 | 250 | 300 | 0,03 | 0,03 | 0,015 |
| 500 | 160 | 75 | 100 | 125 | 200 | 325 | 300 | 400 | 0,05 | 0,05 | 0,03 |
| 630 | 160 | 75 | 125 | 160 | 200 | 400 | 400 | 400 | 0,07 | 0,07 | 0,05 |
| 800 | 160 | 200 | 250 | 282 | 400 | 500 | 400 | 630 | 0,1 | 0,1 | 0,05 |
| 1000 | 160 | 325 | 400 | 500 | 500 | 630 | 630 | 800 | 0,12 | 0,12 | 0,06 |
| 1200 | 160 | 500 | 630 | - | 700 | 800 | 800 | 1000 | 0,16 | 0,16 | 0,08 |

- 1
- 2
- 3
- 4
- 5
- 6
- 7

- 1
- 2
- 3
- 4
- 5
- 6
- 7

RUNDLAUFGENAUIGKEIT DER SPINDELNASE
SPINDLE NOSE CENTERING ACCURACY

Für die Messung der Rundlaufgenauigkeit eines Futters ist zu beachten, dass
1) der Rundlauffehler der Maschinenspindel den unten angegebenen Angaben entspricht
2) das Futter ordnungsgemäß auf der Spindelnase montiert wurde.

To obtain the specified centering accuracy of a chuck mounted on a machine tool it is necessary:

- 1) to ensure the machine spindle nose run-out does not exceed the values specified,
- 2) to meet the basic requirements for correct mounting of the chuck on the spindle nose, according to the operations manual.

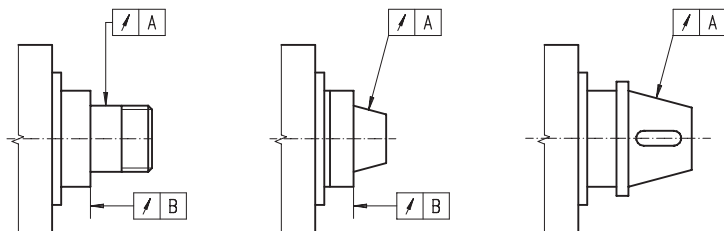

| A · B | | | |
|-------------|---------|------------------|---------|
| 35** | | 32**, 36**, 37** | |
| Ø 80 - 400 | 0,003mm | Ø 80 - 160 | 0,003mm |
| Ø 500 - 630 | 0,005mm | Ø 200 - 800 | 0,005mm |

UNWUCHTWERTE FÜR DREHFUTTER
BALANCE VALUE

35**, 37**

| Futtergröße [mm] | gcm |
|------------------|-----|
| Chuck size [mm] | |
| 80 | 11 |
| 100 | 16 |
| 125 | 23 |
| 160 | 32 |
| 200 | 45 |
| 250 | 63 |
| 315 | 90 |
| 400 | 140 |
| 500 | 300 |
| 630 | 640 |

3404

| Futtergröße [mm] | gcm |
|------------------|-----|
| Chuck size [mm] | |
| 125 | 16 |
| 160 | 32 |
| 200 | 63 |
| 250 | 125 |
| 315 | 250 |

MAX. SPANNKRAFT
TOTAL GRIPPING FORCE

- Die max. Spannkraft ist die Summe aller Kräfte der Backen, die radial auf das stationäre Werkstück wirken. Die angegebenen Spannkraften sind Näherungswerte.
- Voraussetzung hierfür ist ein einwandfreier Zustand des Futters sowie eine ausreichende Schmierung gemäß der Bedienungsanleitung.
- The total gripping force is the sum of all jaw forces acting radially on the stationary workpiece. The specified gripping forces are approximate values.
- They apply to chucks in perfect condition which have been lubricated with greases recommended in the chuck operations manual.

3105, 32**, 35**, 36**, 37**, 38**,
45**, 46**, 47**, 48**

| Futtergröße [mm] | Anzugsmoment [Nm] | Spannkraft [daN] |
|------------------|-----------------------|----------------------------|
| Chuck size [mm] | Torque on wrench [Nm] | Total gripping force [daN] |
| 80 | 35 | 1.000 |
| 100 | 50 | 1.700 |
| 125 | 75 | 2.400 |
| 160 | 120 | 3.100 (2.400*) |
| 200 | 160 | 3.700 (2.900*) |
| 250 | 180 | 4.600 (3.600*) |
| 315 | 200 | 5.500 (4.400*) |
| 400 | 280 | 6.500 (4.900*) |
| 500 | 360 | 7.200 |
| 630 | 460 | 8.000 |
| 800 | 500 | 9.000 |
| 1000 | 500 | 11.500 |
| 1250 | 500 | 12.500 |
| 1400 | 500 | 12.500 |
| 1600 | 500 | 12.500 |
| 1800 | 500 | 12.500 |
| 2000 | 500 | 12.500 |

* Für Typ 3105 • For Type 3105

3404

| Futtergröße [mm] | Anzugsmoment [Nm] | Spannkraft [daN] |
|------------------|-----------------------|----------------------------|
| Chuck size [mm] | Torque on wrench [Nm] | Total gripping force [daN] |
| 125 | 40 | 3.000 |
| 160 | 100 | 6.000 |
| 200 | 160 | 8.500 |
| 250 | 200 | 11.000 |
| 315 | 250 | 13.000 |
| 400 | 280 | 20.000 |
| 500 | 320 | 23.000 |
| 630 | 350 | 25.000 |
| 800 | 350 | 25.000 |
| 1000 | 350 | 25.000 |
| 1200 | 350 | 25.000 |

| Spindelgröße Spindle nose size | A | B max. | C1 | C2 | D | E1 (DIN) | E1 (ISO) | F1 | E2 (DIN) | E2 (ISO) | F2 |
|-----------------------------------|-----|---------|----|--------|----|----------|----------|-------|----------|----------|-------|
| 3 | 92 | 53,983 | 11 | - | 16 | 3xM10 | - | 70,6 | - | - | - |
| 4 | 108 | 63,521 | 11 | - | 20 | 11xM10 | - | 82,6 | - | - | - |
| 5 | 133 | 82,573 | 13 | 14,288 | 22 | 11xM10 | - | 104,8 | 8xM10 | - | 61,9 |
| 6 | 165 | 106,385 | 14 | 15,875 | 25 | 11xM12 | - | 133,4 | 8xM12 | - | 82,6 |
| 8 | 210 | 139,731 | 16 | 17,462 | 28 | 11xM16 | - | 171,4 | 8xM16 | - | 111,1 |
| 11 | 280 | 196,883 | 18 | 19,050 | 35 | 11xM20 | 11xM18 | 235,0 | 8xM20 | 8xM18 | 165,1 |
| 15 | 380 | 285,791 | 19 | 20,638 | 42 | 12xM24 | 12xM22 | 330,2 | 11xM24 | 11xM22 | 247,6 |
| 20 | 520 | 412,795 | 21 | 22,225 | 48 | 12xM24 | - | 463,6 | 11xM24 | - | 368,3 |
| 28 | 725 | 584,248 | 24 | 25,400 | 56 | 12xM30 | - | 647,6 | 11xM30 | - | 530,2 |

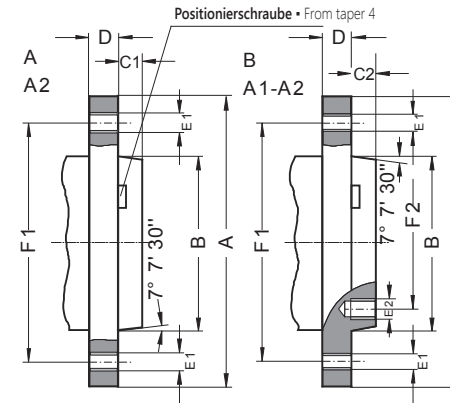
**DIN 55026 - TYP A, TYP B / TYPE A2, TYPE B
 ISO 702/I - TYP A2, TYP A1-A2 / TYPE A2, TYPE A1-A2**

- Typ A: Gewindelöcher im Flansch (äußerer Lochkreis) ohne inneren Lochkreis
- Typ B: Gewindelöcher im Flansch (äußerer Lochkreis) und im inneren Lochkreis
- Maße in Klammern entsprechen ISO 702/I
- Type A: Tapped holes in flange (outer bolt circle) without inner bolt circle
- Type B: Tapped holes in flange (outer bolt circle) and in inner bolt circle
- Dimensions in brackets according to ISO 702/I

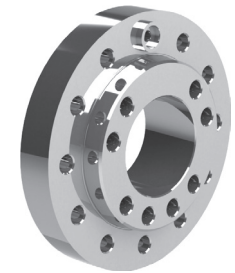

| Spindelgröße Spindle nose size | A | B max. | C | D | E | F |
|-----------------------------------|-----|---------|----|----|------|-------|
| 3 | 102 | 53,983 | 11 | 16 | 3x21 | 75,0 |
| 4 | 112 | 63,521 | 11 | 20 | 3x21 | 85,0 |
| 5 | 135 | 82,573 | 13 | 22 | 4x21 | 104,8 |
| 6 | 170 | 106,385 | 14 | 25 | 4x23 | 133,4 |
| 8 | 220 | 139,731 | 16 | 28 | 4x29 | 171,4 |
| 11 | 290 | 196,883 | 18 | 35 | 6x36 | 235,0 |
| 15 | 400 | 285,791 | 19 | 42 | 6x43 | 330,2 |
| 20 | 540 | 412,795 | 21 | 48 | 6x43 | 463,6 |

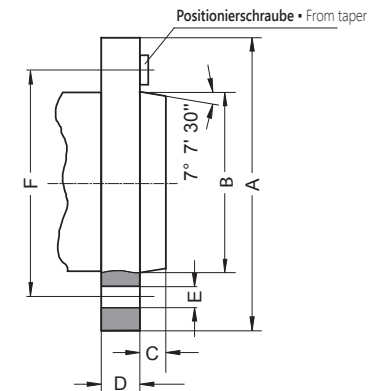
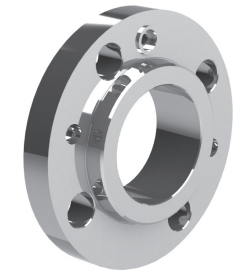

**DIN 55027, ISO 702/III - TYP C / TYPE C
 MIT BAYONETT-SCHEIBE
 WITH BAYONET RING FIXING**

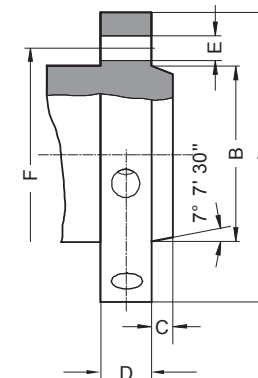
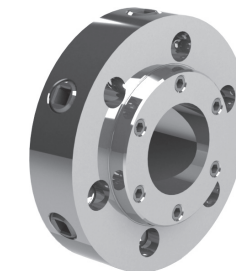
| Spindelgröße Spindle nose size | A | B max. | C | D | E | F |
|-----------------------------------|-----|---------|----|----|--------|-------|
| 3 | 92 | 53,983 | 11 | 32 | 3x15,1 | 70,6 |
| 4 | 117 | 63,521 | 11 | 34 | 3x16,7 | 82,6 |
| 5 | 146 | 82,573 | 13 | 38 | 6x19,8 | 104,8 |
| 6 | 181 | 106,385 | 14 | 45 | 6x23,0 | 133,4 |
| 8 | 225 | 139,731 | 16 | 50 | 6x26,2 | 171,4 |
| 11 | 298 | 196,883 | 18 | 60 | 6x31,0 | 235,0 |
| 15 | 403 | 285,791 | 19 | 70 | 6x35,7 | 330,2 |
| 20 | 546 | 412,795 | 21 | 82 | 6x42,1 | 463,6 |

**DIN 55029, ISO 702/II - TYP D / TYPE C
 CAMLOCK**

- 1
- 2
- 3
- 4
- 5
- 6
- 7

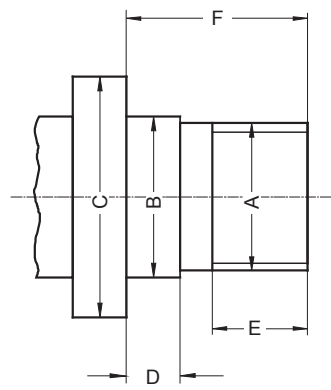
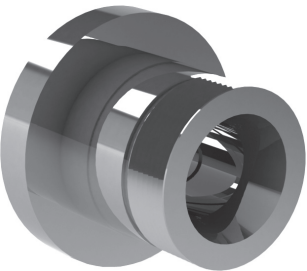
DIN 800 MIT GEWINDE
DIN 800 WITH THREAD



| A | B g5 | C min. | D | E | F |
|---------|------|--------|------|----|----|
| M 20 | 21 | 30 | 6,3 | 10 | 20 |
| M 24 | 25 | 36 | 8,0 | 12 | 24 |
| M 33 | 34 | 50 | 9,0 | 14 | 30 |
| M 39 | 40 | 56 | 10,0 | 16 | 35 |
| M 45 | 46 | 67 | 11,0 | 18 | 40 |
| M 52 | 55 | 80 | 12,0 | 20 | 45 |
| M 60 | 62 | 90 | 14,0 | 22 | 50 |
| M 76x6 | 78 | 112 | 16,0 | 30 | 63 |
| M 105x6 | 106 | 150 | 20,0 | 40 | 80 |

TYP L - LANGKEGEL 7:24
TYPE L - LONG TAPER 7:24

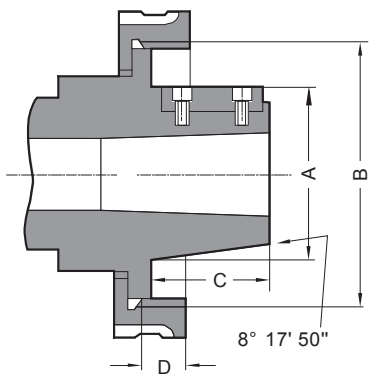
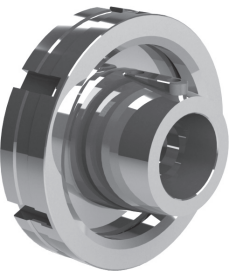

| Spindelgröße Spindle nose size | A +0.051 | B | C | D | Mitnehmer Driving block |
|-----------------------------------|-------------|--------------|-------------|--------|----------------------------|
| | L00 | 69.850 | 3 3/4-6 UNS | 50.800 | 14.288 |
| L0 | 82.550 | 4 1/2-6 UNS | 60.325 | 15.875 | 9.525x44.45 |
| L1 | 104.775 | 6-6 UNS | 73.025 | 19.050 | 15.875x60.32 |
| L2 | 133.350 | 7 3/4-5 UNS | 85.725 | 25.400 | 19.050x73.02 |
| L3 | 165.100 | 10 3/8-4 UNS | 94.425 | 28.575 | 25.400x82.55 |